



WATER-COOLED PACKAGE (R407C SERIES)

Models: FWCP15-100



Contents

Product Nomenclature	2
Feature	3
Engineering Data	4
General Data	8
Operating Range	9
System Schematic Diagram.....	10
Controller's Feature and Algorithm.....	11
Fan Performance Curve	22
Dimension	29
Wiring Diagram	37
Installations	43
Servicing and Maintenance.....	49
Troubleshooting	51

Nomenclature

Water-Cooled Package Air-Conditioner

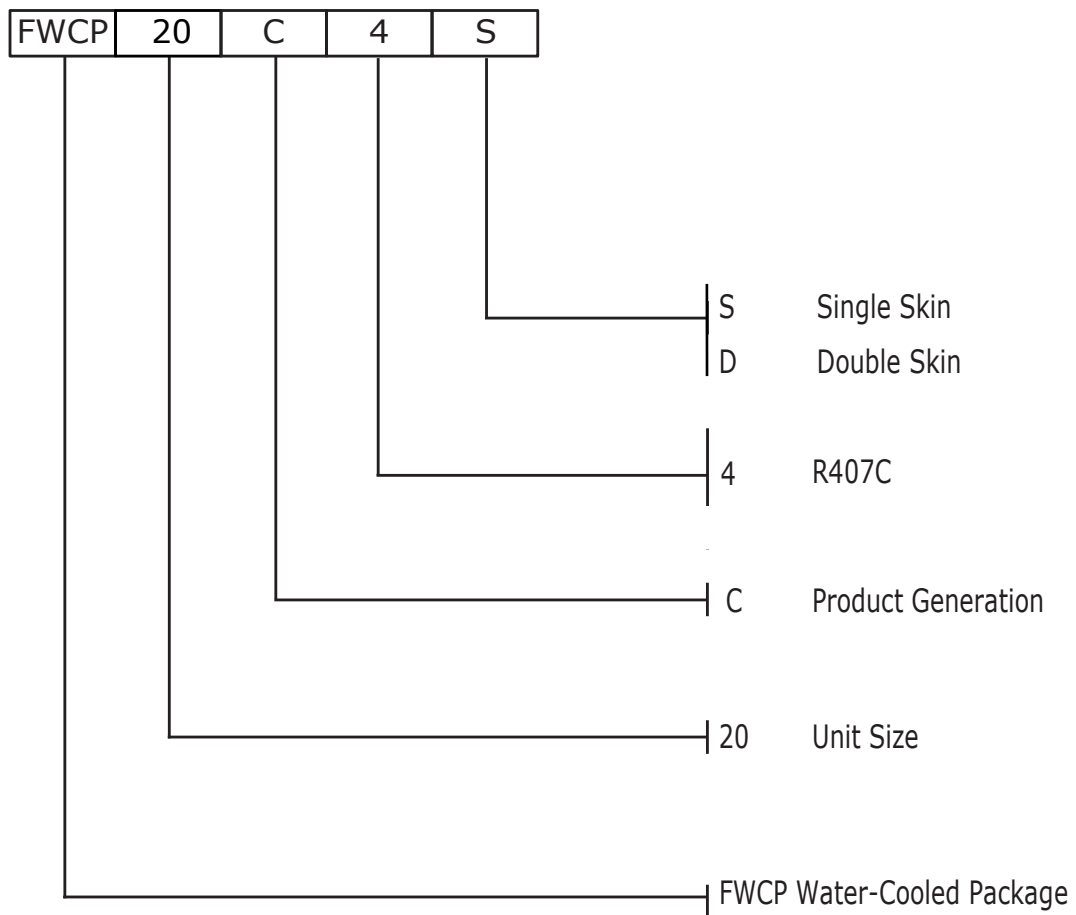

Features

Hermetic Compressor

FWCP series of Water Cooled Packaged Unit is using latest hermetic scroll compressor which possesses the characteristics of high durability, high efficiency, stable and quiet operation.

Multi System

This product uses multi-system design, featuring multiple individual refrigerant circuitry to enable capacity staging. Thus, part loading is possible during off-peak conditions which enable more energy saving.

Elegant Outlook

Single-tone paneling with powder paint coating offers excellent anti-rust and excellent finishing.

Easy Installation

Direction of water connection pipe is changeable to suit site conditions, providing flexibility in installation.

Microcomputer controlled

Multiple modes supported (can choose between Fan, Water Pump, Cooling, Heating, Compressor) with temperature range of 16°C ~ 30°C. The controller is equipped with LCD display and supports Energy Saving, Alarm on system error, Self-Diagnosis, and is able to display Set Temperature or Return Air Temperature.

Engineering Data

Model	FWCP	15	20	25	30	
Total Cooling Capacity	kW	37.4	48	64	78	
	Btu/h	127,500	164,000	219,000	265,000	
Cooling Capacity Staging	%	0,100	0,50,100			
Air Volume	CMH	6,750	8,000	11,000	13,200	
	CFM	3,971	4,709	6,470	7,765	
ESP	Pa	100	120	150	200	
Sound Pressure Level	dB(A)	66	66	68	69	
Power Supply	V/Ph/Hz	380~415/3/50				
R407C Amount	kg	5.0	4.0 x2	4.7 x2	5.0 x2	
Compressor Type	Hermetic Scroll					
Evaporator Type	Fin-Tube					
Condenser	Type	Shell & Tube				
	Water Flow Rate	m ³ /h	7.7	10.0	13.6	15.8
	Water Pressure Drop	mH ₂ O	1.5	2.60	2.70	2.80
Fan	Type	Centrifugal Fan				
	Drive	Belt Driven				
Filter	Size x Quantity	mm x pcs	396*329*6	396*329 x8	396*329 x4 599*329 x4	599*329 x8
Condensate Water Pipe	Intermediate Drain Pan	mm(in)	DN25(1")			
	Bottom Drain Pan	mm(in)	DN25(1")			
Cooling Water Pipe Size (Inner Groove)	DN50(2")					
Dimension	Width	mm	1,550	1,850	1,850	1,850
	Length	mm	1,120	1,120	1,120	1,120
	Height	mm	1,622	1,622	1,826	2,029
Weight	kg	646	820	847	900	

Note:

1. Nominal cooling capacity is tested under nominal air flow and under the following conditions:
 - a) Indoor condition: 27°C DB / 19°C WB
 - b) Inlet water: 30°C
 - c) Outlet water: 35°C
2. Nominal cooling capacity does not include heat generated from fan motor and nominal air flow is referring to high speed air flow under standard condition.
3. ESP is referring to external static pressure for standard equipment.
4. Nominal power input is based on 400 V.
5. The manufacturer reserves the right to change the specifications without prior notice.

General Data For Water Cooled Package (R407C)

Model	FWCP		35	40	45	50
Total Cooling Capacity	kW		92	107	123	139
	Btu/h		313,000	365,000	421,000	473,000
Cooling Capacity Staging	%		0,40,80,100	0,33,67,100	0,29,58,87,100	0,29,58,87,100
Air Volume	CMH		17,000	19,800	22,000	24,600
	CFM		10,000	11,645	12,940	14,470
ESP	Pa		250	250	300	300
Sound Pressure Level	dB(A)		74	75	75	76
Power Supply	V/Ph/Hz		380~415/3/50			
R407C Amount	kg		4.75 x2+3.8	5.0 x3	4.0 x3+4.3	4.3 x3+4.1
Compressor Type	Hermetic Scroll					
Evaporator Type	Fin-Tube					
Condenser	Type	Shell & Tube				
	Water Flow Rate	m ³ /h	20.4	23.7	27.3	31.0
	Water Pressure Drop	mH ₂ O	2.90	2.90	2.96	2.81
Fan	Type	Centrifugal Fan				
	Drive	Belt Driven				
Filter	Size x Quantity	mm x pcs	650*383 x8		650*383 x10	
Condensate Water Pipe	Intermediate Drain Pan	mm(in)	DN25(1")			
	Bottom Drain Pan	mm(in)	DN25(1")			
Cooling Water Pipe Size (Inner Groove)			DN50(2")		DN65(2 1/2")	
Dimension	Width	mm	2,048	2,048		2,440
	Length	mm	1,103	1,103		1,263
	Height	mm	2,130	2,130		2,181
Weight	kg		950	1,010		1,235

Note:

- Nominal cooling capacity is tested under nominal air flow and under the following conditions:
 - Indoor condition: 27°C DB / 19°C WB
 - Inlet water: 30°C
 - Outlet water: 35°C
- Nominal cooling capacity does not include heat generated from fan motor and nominal air flow is referring to high speed air flow under standard condition.
- ESP is referring to external static pressure for standard equipment.
- Nominal power input is based on 400 V.
- The manufacturer reserves the right to change the specifications without prior notice.

General Data For Water Cooled Package (R407C)

Model	FWCP		55	60	65	70
Total Cooling Capacity	kW		149	166	180	193
	Btu/h		508,000	567,000	613,000	658,000
Cooling Capacity Staging	%		0,25,50, 75,100	0,25,58, 87,100	0,22,44, 66,88,100	0,20,40, 60, 80,100
Air Volume	CMH		26,400	27,600	28,800	33,000
	CFM		15,530	16,235	16,940	19,410
ESP	Pa		350	350	350	350
Sound Pressure Level	dB(A)		77	77	78	79
Power Supply	V/Ph/Hz		380~415/3/50			
R407C Amount	kg		6.5 x4.0	5.0 x3+6.3	5.8 x4+4.3	5.6 x5
Compressor Type	Hermetic Scroll					
Evaporator Type	Fin-Tube					
Condenser	Type	Shell & Tube				
	Water Flow Rate	m ³ /h	33.1	35.0	39.8	42.8
	Water Pressure Drop	mH ₂ O	4.28	4.20	4.20	5.00
Fan	Type	Centrifugal Fan				
	Drive	Belt Driven				
Filter	Size x Quantity	mm x pcs	650*383 x10	815*461 x8 815*216 x2		
Condensate Water Pipe	Intermediate Drain Pan	mm(in)	DN25(1")			
	Bottom Drain Pan	mm(in)	DN25(1")			
Cooling Water Pipe Size (Inner Groove)			DN80(3")			
Dimension	Width	mm	2,440	2,580	2,580	2,580
	Length	mm	1,263	1,263	1,263	1,263
	Height	mm	2,181	2,461	2,461	2,461
Weight	kg		1,250	1,300	1,350	1,375

Note:

- Nominal cooling capacity is tested under nominal air flow and under the following conditions:
 - Indoor condition: 27°C DB / 19°C WB
 - Inlet water: 30°C
 - Outlet water: 35°C
- Nominal cooling capacity does not include heat generated from fan motor and nominal air flow is referring to high speed air flow under standard condition.
- ESP is referring to external static pressure for standard equipment.
- Nominal power input is based on 400 V.
- The manufacturer reserves the right to change the specifications without prior notice.

General Data For Water Cooled Package (R407C)

Model	FWCP		80	90	100
Total Cooling Capacity	kW		216	245	272
	Btu/h		733,000	837,000	925,000
Cooling Capacity Staging	%		0,22,44,66,83,100	0,20,40,60,80,100	0,17,33,50,66,83,100
Air Volume	CMH		36,600	41,000	46,200
	CFM		21,540	24,100	27,100
ESP	Pa		350	350	350
Sound Pressure Level	dB(A)		85	87	89
Power Supply	V/Ph/Hz		380~415/3/50		
R407C Amount	kg		5.0 x2+6.3 x3	6.3 x5	6.3 x6
Compressor Type	Hermetic Scroll				
Evaporator Type	Fin-Tube				
Condenser	Type	Shell & Tube			
	Water Flow Rate	m ³ /h	46.2	52.3	58.7
	Water Pressure Drop	mH ₂ O	4.10	5.30	7.00
Fan	Type	Centrifugal Fan			
	Drive	Belt Driven			
Filter (Single Skin)	Size x Quantity	mm x pcs	815*461 x10	815*461 x10 815*300 x2	815*461 x10 815*300 x4
Filter (Double Skin)	Size x Quantity	mm x pcs	815*461 x10 815*300 x2		815*461 x10 815*300 x4
Condensate Water Pipe	Intermediate Drain Pan	mm(in)	DN40(1 1/2")		
	Bottom Drain Pan	mm(in)	DN25(1")		
Cooling Water Pipe Size (Inner Groove)		DN80(3")			
Dimension	Width	mm	3,440 (Single Skin) 3,440 (Double Skin)		3,946 (Single Skin) 3,946 (Double Skin)
		mm	1,420 (Single Skin) 1,473 (Double Skin)		1,420 (Single Skin) 1,473 (Double Skin)
	Height	mm	2,431 (Single Skin) 2,509 (Double Skin)		2,463 (Single Skin) 2,532 (Double Skin)
Weight	kg		1,650 (Single Skin) 1,900 (Double Skin)	1,800 (Single Skin) 2,050 (Double Skin)	2,100 (Single Skin) 2,390 (Double Skin)

Note:

- Nominal cooling capacity is tested under nominal air flow and under the following conditions:
 - Indoor condition: 27°C DB / 19°C WB
 - Inlet water: 30°C
 - Outlet water: 35°C
- Nominal cooling capacity does not include heat generated from fan motor and nominal air flow is referring to high speed air flow under standard condition.
- ESP is referring to external static pressure for standard equipment.
- Nominal power input is based on 400 V.
- The manufacturer reserves the right to change the specifications without prior notice.

Electrical Data - Water Cooled Package R407C

VOLT	ITEM		FWCP15	FWCP20	FWCP25	FWCP30	FWCP35
400V	TOTAL POWER INPUT	kW	8.94	11.80	16.80	18.80	23.40
	TOTAL LOAD AMP(RLA)	A	17.60	24.50	34.40	36.80	46.30
	MAXIMUM RUNNING AMP(MRA)	A	30.40	36.30	47.80	59.20	71.10
	COMPRESSOR POWER INPUT	kW	7.00	9.90	13.20	14.00	17.00
	COMPRESSOR RATED LOAD(RLA)	A	14.20	21.00	28.00	28.50	35.30
	FAN POWER INPUT	kW	1.94	1.90	3.60	4.80	6.40
	FAN RATED LOAD AMP(RLA)	A	3.4	3.50	6.40	8.30	11.00

VOLT	ITEM		FWCP40	FWCP45	FWCP50	FWCP55	FWCP60
400V	TOTAL POWER INPUT	kW	26.20	33.40	36.20	40.40	43.40
	TOTAL LOAD AMP(RLA)	A	53.00	64.60	71.30	78.00	86.00
	MAXIMUM RUNNING AMP(MRA)	A	78.30	104.00	104.00	123.90	111.20
	COMPRESSOR POWER INPUT	kW	19.80	24.80	27.60	28.00	31.00
	COMPRESSOR RATED LOAD(RLA)	A	42.00	50.00	56.70	56.90	64.90
	FAN POWER INPUT	kW	6.40	8.60	8.60	12.40	12.40
	FAN RATED LOAD AMP(RLA)	A	11.00	14.60	14.60	21.10	21.10

VOLT	ITEM		FWCP65	FWCP70	FWCP80	FWCP90	FWCP100
400V	TOTAL POWER INPUT	kW	44.20	51.90	56.20	66.40	80.10
	TOTAL LOAD AMP(RLA)	A	85.30	99.70	116.20	139.50	167.70
	MAXIMUM RUNNING AMP(MRA)	A	136.10	157.30	174.80	200.70	240.80
	COMPRESSOR POWER INPUT	kW	31.80	35.10	43.80	49.60	59.50
	COMPRESSOR RATED LOAD(RLA)	A	64.20	71.20	95.10	111.00	133.20
	FAN POWER INPUT	kW	12.40	16.80	12.40	16.80	20.60
	FAN RATED LOAD AMP(RLA)	A	21.10	28.50	21.10	28.50	34.50

Operating Range

Cooling

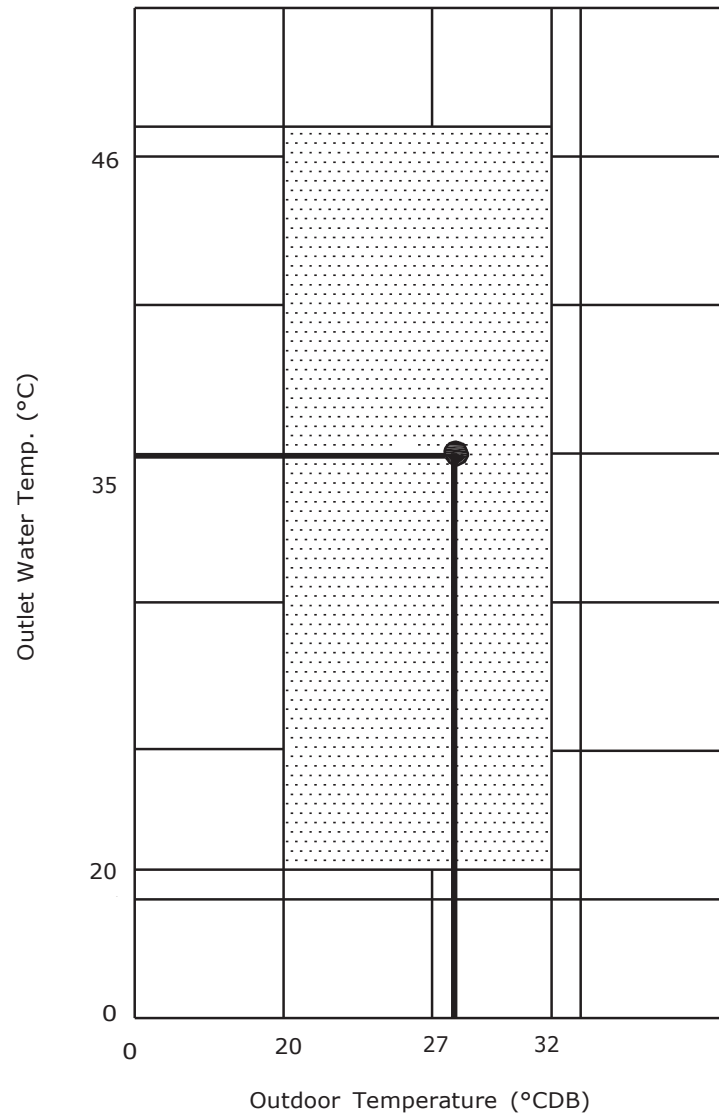

System Schematic Diagram

FWCP 15 ~ 100

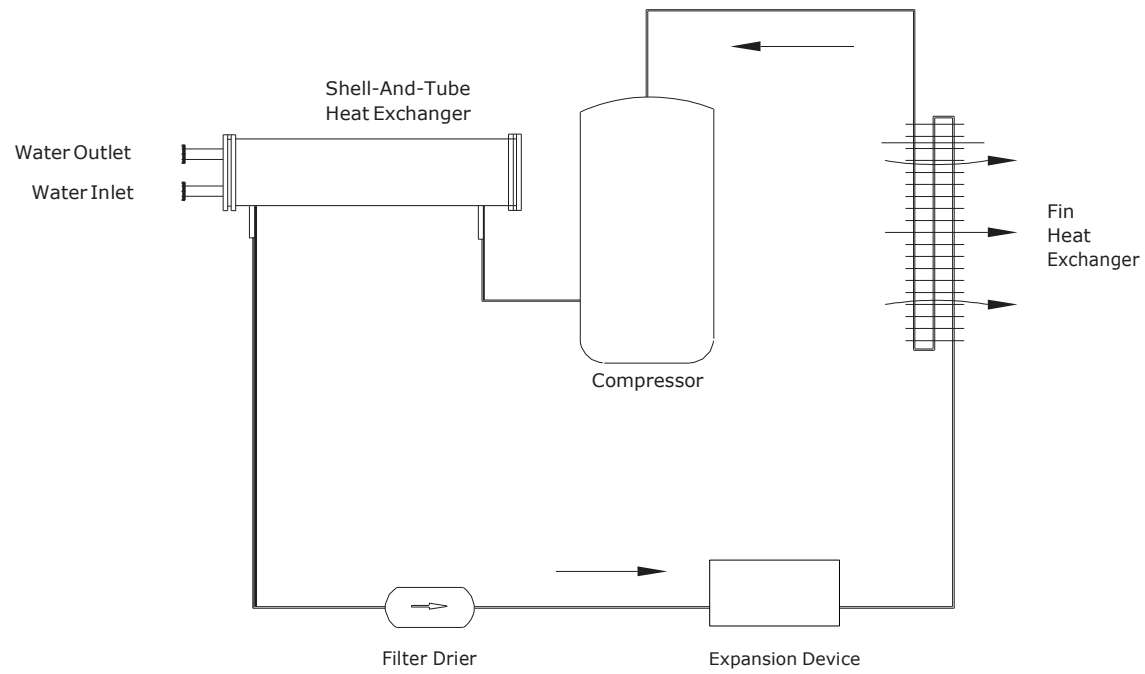

Controller's Features and Algorithm

LCD Control Panel Operation Guide

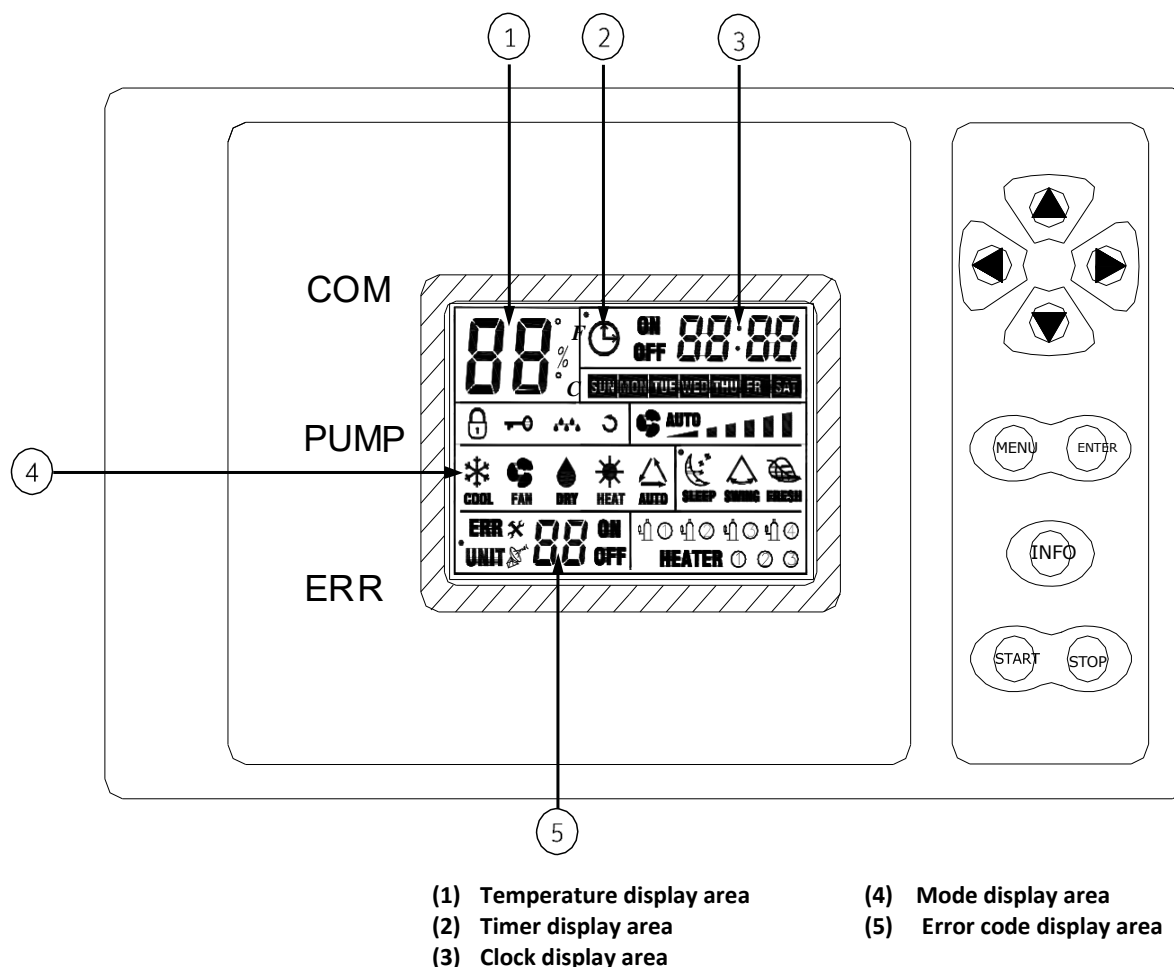

The multi-color backlighting LCD wallpad accept the command from the membrane switch to control the following :-

- Mode: Cool → Fan → Heat
- Room temperature display
- Real time clock [RTC] display
- Programmable on/off timer
- Comp operation status display
- Indoor fan operation status display
- Remote ON/OFF display
- Alarm status and its error code display
- Buzzer beeping upon key press acknowledgement
- Battery to maintain the RTC operation upon power failure
- Key lock function

Control Parameter Settings

Press MENU key on the main screen will activate the system to enter into the desired submenu according to the sequence of Set Temp [not available for fan mode] → Mode setting → RTC setting → On timer setting → Off timer setting → Set Temp [not available for fan mode]. Upon completion of parameter settings, press ENTER key to exit. Details of operation are as follow:

1. Set temperature

Press MENU key once in cool or heat mode to enter into this submenu. Temperature display section will flash the temp setting of the current mode. Press ▲ or ▼ key to adjust the set temperature. Upon completion of editing, press ENTER key to exit.

2. Mode

Press MENU key twice to enter into this submenu. Mode display section will flash the current mode setting. Press ▲ or ▼ key to change the mode setting. Upon completion of editing, press ENTER key to exit.

3. RTC



Press MENU key three times to enter into this submenu with  symbol flashing. Press ▲ or ▼

key once will increase or decrease the RTC setting in 1 minute incremental. Hold ▲ or ▼ key for 3 second will change the RTC setting in 1 hour incremental. Press ◀ or ▶ key to change day of week setting. Upon completion of editing, press ENTER key to exit.

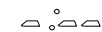









4. On timer



Press MENU key four times to enter into this submenu with  ON symbol flashing. If on timer for the current day is empty, timer display area shows 

Press ▲ or ▼ key once will activate the timer. Once the timer is activated, press ▲ or ▼ key once will increase or decrease the timer setting in 1 minute incremental. Hold ▲ or ▼ key for 3 second will change the timer setting in 1 hour incremental. Press ◀ or ▶ key to change day of week the timer to be programmed. Press INFO key to cancel the timer setting. Upon completion of editing, press ENTER key to exit.

Should there be on timer being programmed  symbol will light up. Should there be on timer available for the current day waiting for execution,  ON the symbol will light up.

5. Off timer



Press MENU key five times to enter into this submenu  OFF symbol flashing. If off timer for the current day is empty, timer display area shows . Press  or  key once will activate the timer. Once the timer is activated, press  or  key once will increase or decrease the timer setting in 1 minute incremental. Hold  or  key for 3 sec will change the timer setting in 1 hour incremental. Press  or  key to change day of week the timer to be programmed. Press INFO key to cancel the timer setting. Upon completion of editing, press ENTER key to exit.

Should there be off timer being programmed  symbol will light up. Should there be on timer available for the current day waiting for execution,  OFF the symbol will light up.

6. Key lock

Press MENU and ENTER keys on the main menu for 3 sec to activate this function with symbol  light up. Follow the same sequence to exit key lock. In key lock mode, user is allowed to access to On/Off key only.

7. Information

Press INFO key on the main menu for information browsing. Press  or  key to select the required information as follow:

Temperature display section	Timer display section	Remarks
C0	Main board DIP switch setting	Display position 1-8 [correspond to bit7-bit0] in hexadecimal format.
C1	Return air temperature	AD1 temp on main board
C2	N/A	N/A
C3	N/A	N/A
C4	N/A	N/A
C5	N/A	N/A
C6	N/A	N/A
C7	N/A	N/A

Press ENTER key to exit.

8. Error code display

Back light color will turn to red when there is any system failure. EER light will turn on and error display section will show the relevant error code as follow:

Error code	Remarks
1	Phase failure [manual reset]
2	Indoor fan failure [manual reset]
3	Flow switch failure [manual reset]
4	Water pump failure [manual reset]
5	Comp 1 high pressure [manual reset]
6	Comp 1 low pressure [manual reset]
7	Comp 2 high pressure [manual reset]
8	Comp 2 low pressure [manual reset]
9	Comp 3 high pressure [manual reset]
	- FWCP 20-90 > Comp 3 high pressure
	- FWCP 100 > Comp 3 / Comp 4 high pressure
10	Comp 3 low pressure [manual reset]
	- FWCP 20-90 > Comp 3 low pressure
	- FWCP 100 > Comp 5 / Comp 6 low pressure
11	Comp 4 high pressure [manual reset]
	- FWCP 20-60 > Comp 4 high pressure
	- FWCP 65-90 > Comp 4 / Comp 5 high pressure
	- FWCP 100 > Comp 5 / Comp 6 high pressure
12	Comp 4 low pressure [manual reset]
	- FWCP 20-60 > Comp 4 low pressure
	- FWCP 65-90 > Comp 4 / Comp 5 low pressure
	- FWCP 100 > Comp 5 / Comp 6 low pressure
13	N/A
14	N/A
15	N/A
16	Return air sensor failure [auto reset]
17	N/A
18	N/A
19	N/A
20	N/A
21	N/A
22	N/A
23	N/A
24	N/A
25	N/A
26	N/A
27	N/A
28	N/A

Manual reset: When there is failure occurred, press MENU and ▼ key for 3 sec to clear the errors.

9. Remote on/off
If the remote on/off input is opened, OFF will be shown on the timer display section.
Main board will go into standby mode even if the wallpad is at on status.

10. Communication indication
Communication LED will flash at regular speed if the communication between wallpad and main board is healthy.

Modbus Protocol

Networking (Building Automation System)

Topology

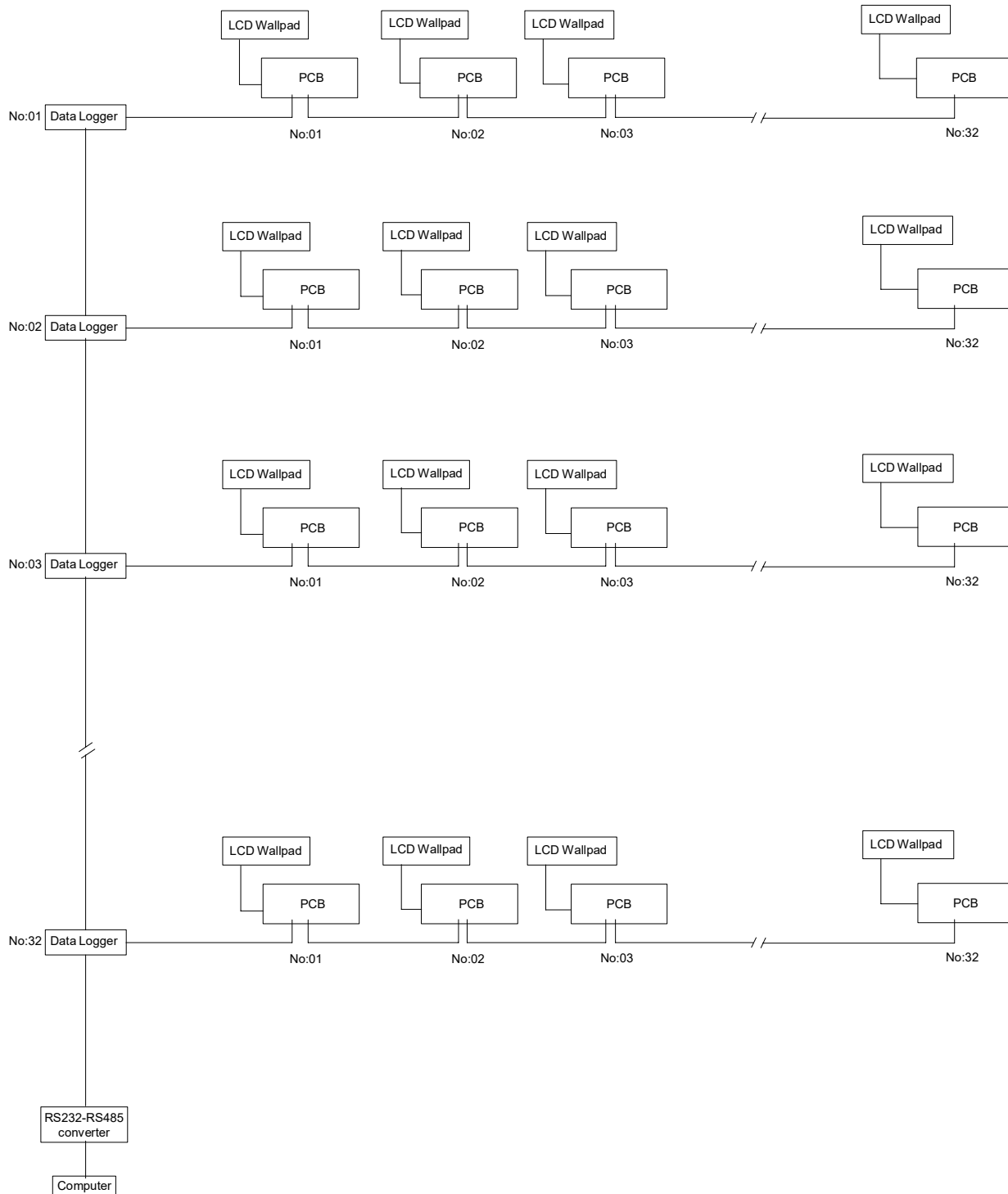

General Modbus protocol

System Setup		
Connection port	:	RS-485
Communication way	:	Half duplex
Communication format	:	Asynchronous Serial Communication
Baud rate	:	1 start bit, 8 data bits, 1 stop bit
Baud rate	:	9600bps
Communication method	:	Master-slave (PC or master controller as Master, others as Slave)
BUS standard	:	MODBUS protocol, RTU (Remote Terminal Unit) mode
Error checking	:	CRC-16
Function Code	Description	Definition
01 (0x01)	Read Coils	This function code is used to read from 1 to 2000 contiguous status of coils in a remote device.
02 (0x02)	Read Discrete Inputs	This function code is used to read from 1 to 2000 contiguous status of discrete inputs in a remote device.
03 (0x03)	Read Holding Registers	This function code is used to read the contents of a contiguous block of holding registers in a remote device.
04 (0x04)	Read Input Registers	This function code is used to read from 1 to approx. 125 contiguous input registers in a remote device.
05 (0x05)	Write Single Coil	This function code is used to write a single output to either ON or OFF in a remote device.
06 (0x06)	Write Single Register	This function code is used to write a single holding register in a remote device
15 (0x0F)	Write Multiple Coils	This function code is used to force each coil in a sequence of coils to either ON or OFF in a remote device.
16 (0x10)	Write Multiple registers	This function code is used to write a block of contiguous registers (1 to approx. 120 registers) in a remote device.

Error Code	Description	Definition
02 (0x02)	Illegal Data Address	The data address (register number) received in the query is not an allowed address
04 (0x04)	Illegal Write Data	The data written in the query is not valid

Control point list

COIL(bit) Read 01 (0x01) Write 05 (0x05) Write 15 (0x0F)	Address	Description	
	1	On/Off unit	Apply to both water-cooled and air-cooled system
	2	Reserved	
	3	Reserved	
	4	Reserved	
	5	Reserved	
	6	Reserved	
	7	Reserved	
	8	Reserved	

DISCRETE STATUS(bit) Read 02 (0x02)	Address	Water-cooled package	Air-cooled package	Description
	4000	#1 compressor	#1 compressor	Read discrete inputs 0 – Not in operation 1 – In operation
	4001	#2 compressor	#2 compressor	
	4002	#3 compressor	#3 compressor	
	4003	#4 compressor	#4 compressor	
	4004	#1 electric heater	#1 electric heater	
	4005	#2 electric heater	#2 electric heater	
	4006	#3 electric heater	#3 electric heater	
	4007	Indoor blower	Medium speed	
	4008	Reserved	Reserved	
	4009	Water pump	Low speed	
	4010		High speed	
	4011		Reserved	
	4012		#1 outdoor fan	
	4013		#2 outdoor fan	
	4014		#3 outdoor fan	
4015		#4 outdoor fan		

DISCRETE STATUS(bit) Read 02 (0x02)	Address	Water-cooled package	Air-cooled package	Description	
	1	Power failure	Power failure		Read discrete inputs 0 – No error 1 – Error
	2	Indoor blower error	Indoor blower error		
	3	Flow switch error	1# outdoor fan error		
	4	Water pump error	2# outdoor fan error		
	5	1# High pressure error	3# outdoor fan error		
	6	1# Low pressure error	4# outdoor fan error		
	7	2# High pressure error	1# High pressure error		
	8	2# Low pressure error	1# Low pressure error		
	9	3# High pressure error	2# High pressure error		
	10	3# Low pressure error	2# Low pressure error		
	11	4# High pressure error	3# High pressure error		
	12	4# Low pressure error	3# Low pressure error		
	13	1# Electric heater error	4# High pressure error		
	14	2# Electric heater error	4# Low pressure error		
	15	3# Electric heater error	Electric heater error		
	16	Return air temp sensor error	Return air temp sensor error		
	17	Entering water temp sensor error	Outdoor air temp sensor error		
	18	Leaving water temp sensor error	Supply air temp sensor error		
	19	1# Indoor coil temp sensor error	1# Indoor coil temp sensor error		
	20	2# Indoor coil temp sensor error	2# Indoor coil temp sensor error		
	21	3# Indoor coil temp sensor error	3# Indoor coil temp sensor error		
	22	4# Indoor coil temp sensor error	4# Indoor coil temp sensor error		
	23	Low water temperature protection	Reserved		
	24	Large water temp diff protection	Reserved		
	25	1# Indoor coil anti-freeze protection	1# Indoor coil anti-freeze protection		
	26	2# Indoor coil anti-freeze protection	2# Indoor coil anti-freeze protection		
	27	3# Indoor coil anti-freeze protection	3# Indoor coil anti-freeze protection		
	28	4# Indoor coil anti-freeze protection	4# Indoor coil anti-freeze protection		
	29		1# Refrigerant leak protection		
	30		2# Refrigerant leak protection		
	31		3# Refrigerant leak protection		
	32		4# Refrigerant leak protection		
	33		1# Outdoor coil temp sensor error		
	34		2# Outdoor coil temp sensor error		
	35		3# Outdoor coil temp sensor error		
	36		4# Outdoor coil temp sensor error		
	37		1# Indoor coil overheat protection		
	38		2# Indoor coil overheat protection		
	39		3# Indoor coil overheat protection		
	40		4# Indoor coil overheat protection		

INPUT REGISTER Read 04 (0x04)		Address	Descriptions		
		1	Software code: 0x0001		
		2	System model code 1: - Water-cooled package : 0x00a0 Air-cooled package : 0x0080 (Cooling model) : 0x0081 (Heatpump model)		
		3	System model code 2:- D00 : 1-With electric heater D01 : 1-With fresh air D02 : 1-With domestic hot water D03 : 1-Heat only model D04 to D15 : Reserved		
		Address	Water-cooled package	Air-cooled package	Descriptions
	100	Return air temperature	Return air temperature		Read Input Registers (Show value = Actual value*10)
	101	Entering water temperature	Outdoor air temperature		
	102	Leaving water temperature	Supply air temperature		
	103	1# Indoor coil temperature	1# Indoor coil temperature		
	104	2# Indoor coil temperature	2# Indoor coil temperature		
	105	3# Indoor coil temperature	3# Indoor coil temperature		
	106	4# Indoor coil temperature	4# Indoor coil temperature		
	107		1# Outdoor coil temperature		
	108		2# Outdoor coil temperature		
	109		3# Outdoor coil temperature		
	110		4# Outdoor coil temperature		

HOLDING REGISTER Read 03 (0x03) Write 06 (0x06) Write 16 (0x10)	Address	Descriptions	
	1	Set temperature (Air conditioning)	
	2	Reserved	
	3	Mode of operation:- 1 - Cooling 2 - Fan only 4 - Dehumidification 8 - Heating 16 - Auto	
	4	Indoor blower speed:- 1 - Low speed 2 - Medium speed 4 - High speed 8 - Auto	
	5	Reserved	
	6	Reserved	
Address	Water-cooled package	Air-cooled package	Descriptions
2000	Return air temperature correction	Return air temperature correction	Temperature correction range (-5°C to 5°C)
2001	Entering water temp correction	Outdoor air temperature correction	
2002	Leaving water temp correction	Supply air temperature correction	
2003	1# Indoor coil temp correction	1# Indoor coil temp correction	
2004	2# Indoor coil temp correction	2# Indoor coil temp correction	Lock features is applicable only when use with LCD wallpad type-T1
2005	3# Indoor coil temp correction	3# Indoor coil temp correction	
2006	4# Indoor coil temp correction	4# Indoor coil temp correction	
2007	System On/Off lock	1# Outdoor coil temp correction	
2008	Mode of operation lock	2# Outdoor coil temp correction	
2009	Set temperature lock	3# Outdoor coil temp correction	
2010	Indoor blower speed lock	4# Outdoor coil temp correction	
2011		System On/Off lock	
2012		Mode of operation lock	
2013		Set temperature lock	
2014		Indoor blower speed lock	

Fan Performance Curve

FWCP 15

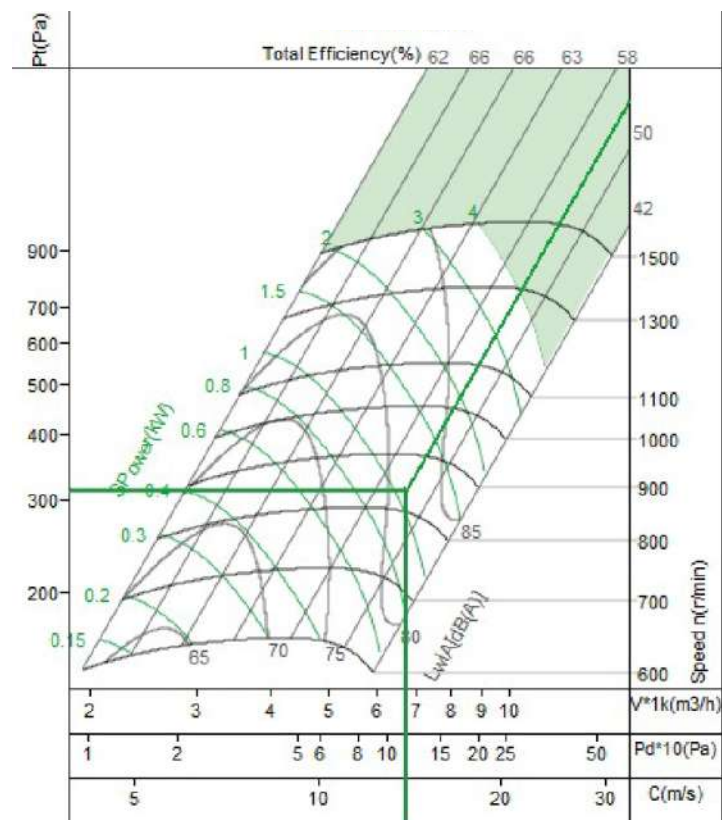

Fan Performance Curve

FWCP 30

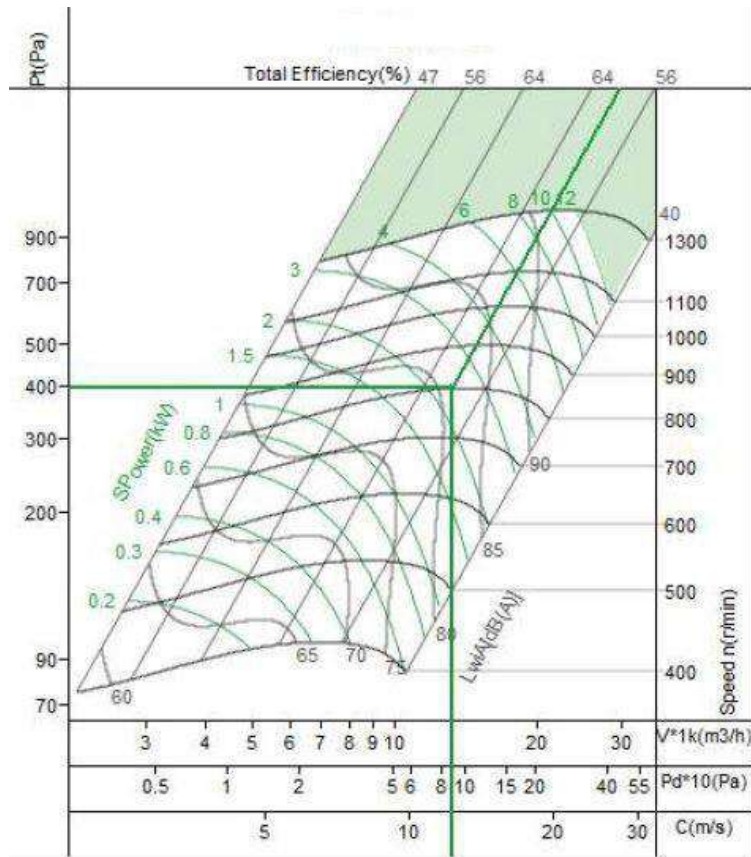

FWCP 35

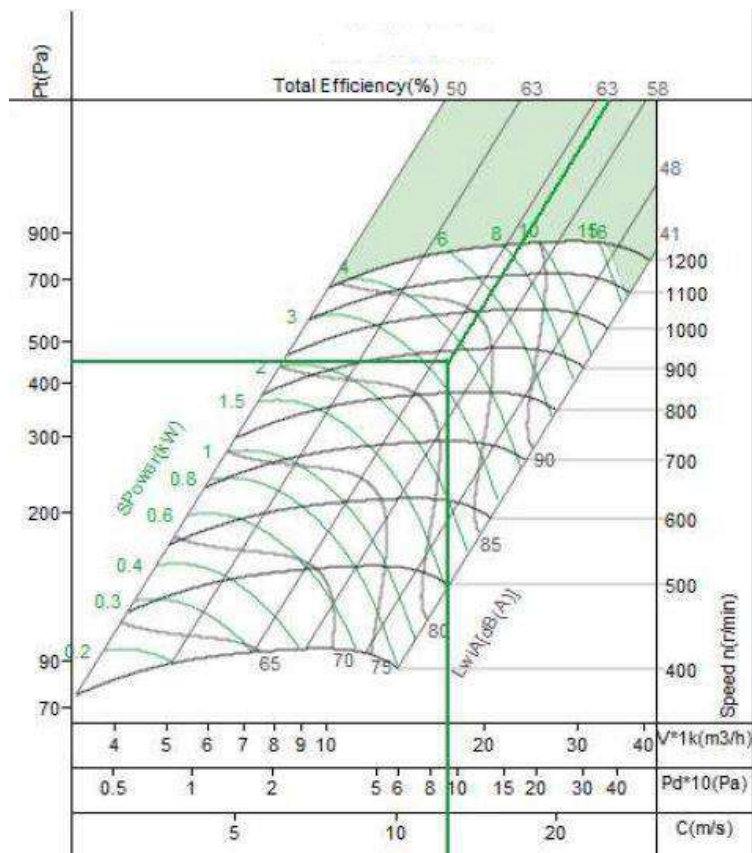

Fan Performance Curve

FWCP 40

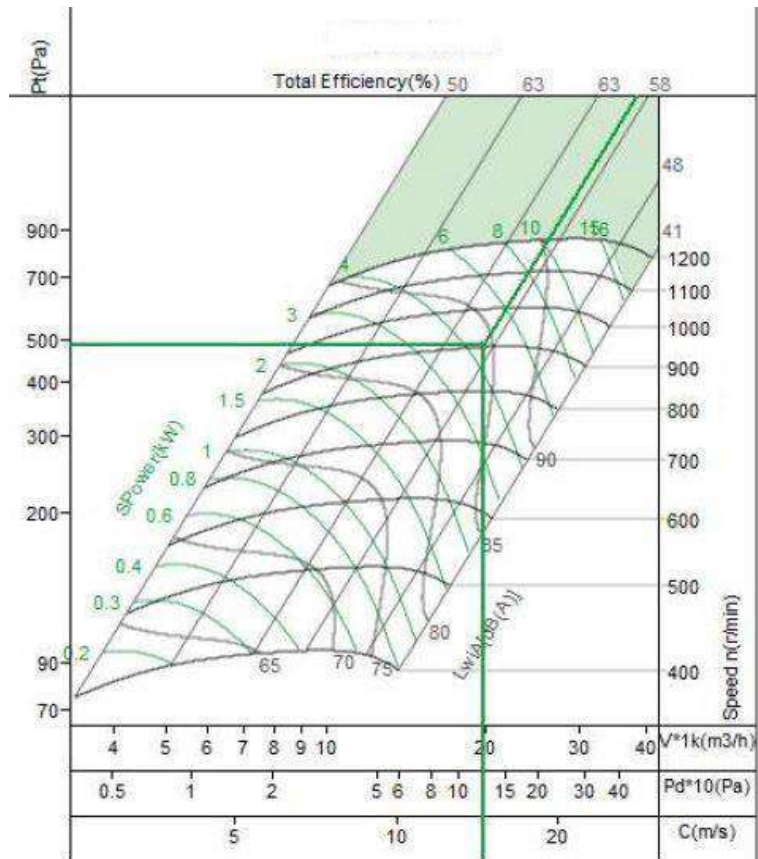

FWCP 45

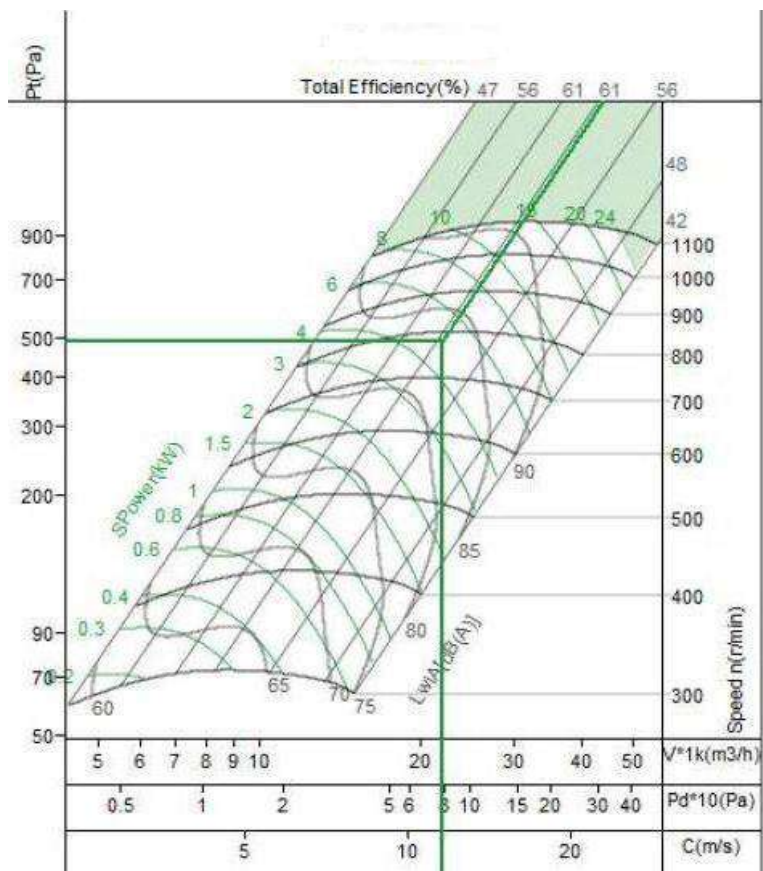

Fan Performance Curve

FWCP 50

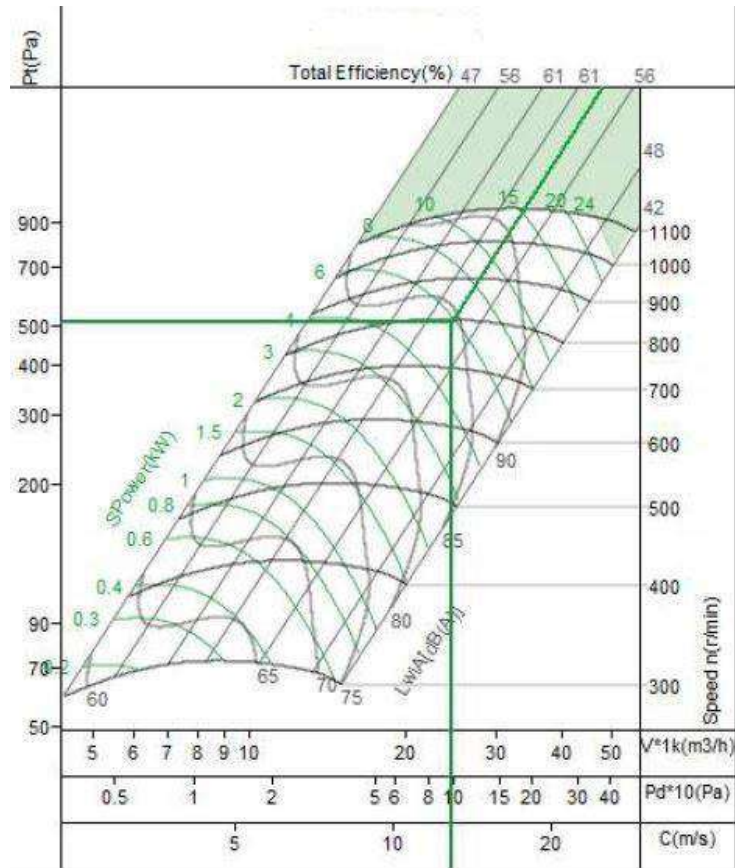

FWCP 55

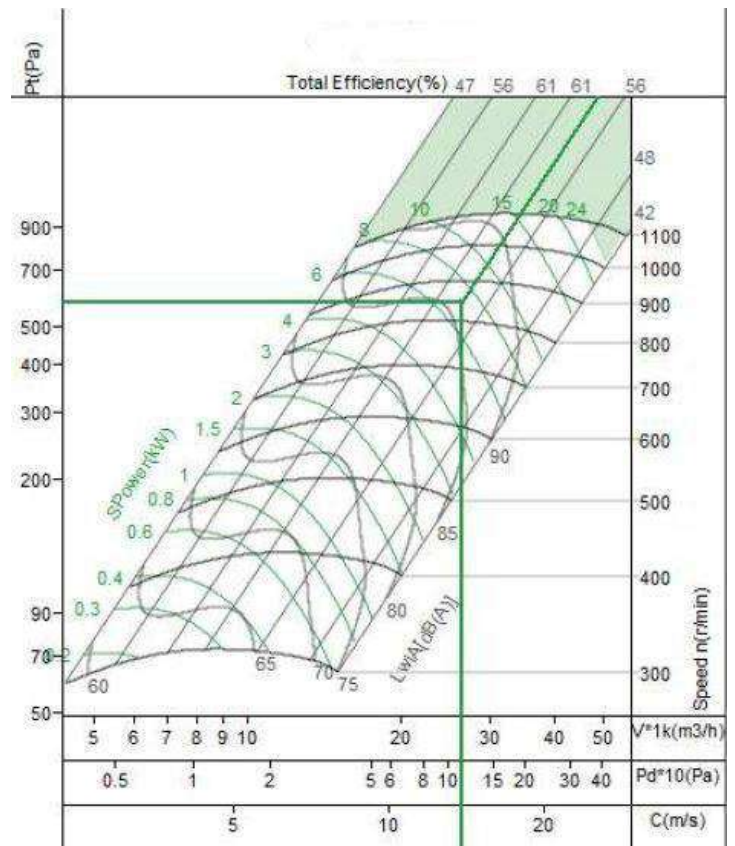

Fan Performance Curve

FWCP 60

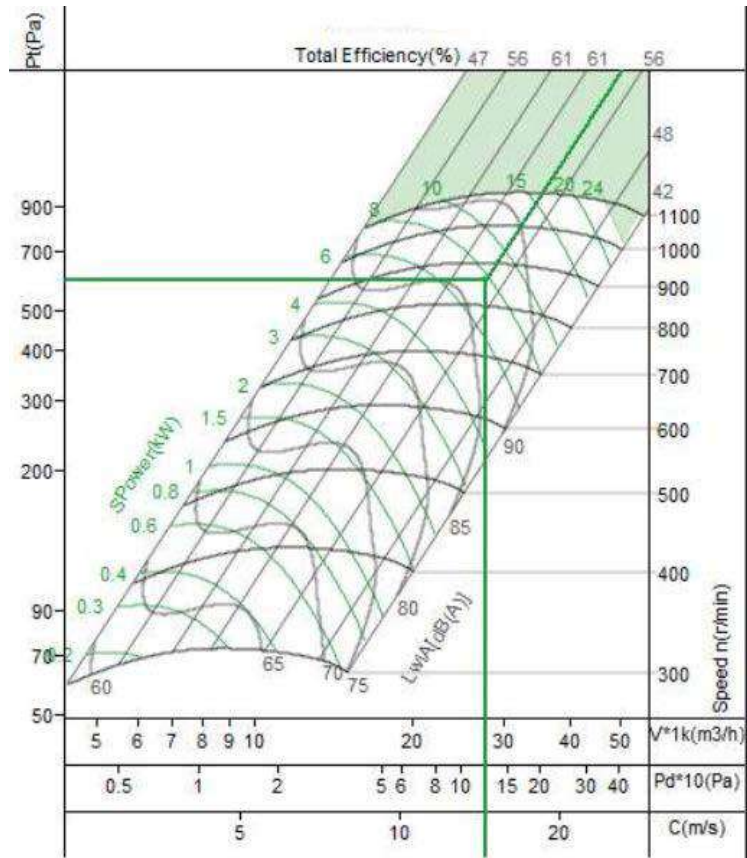

FWCP 65

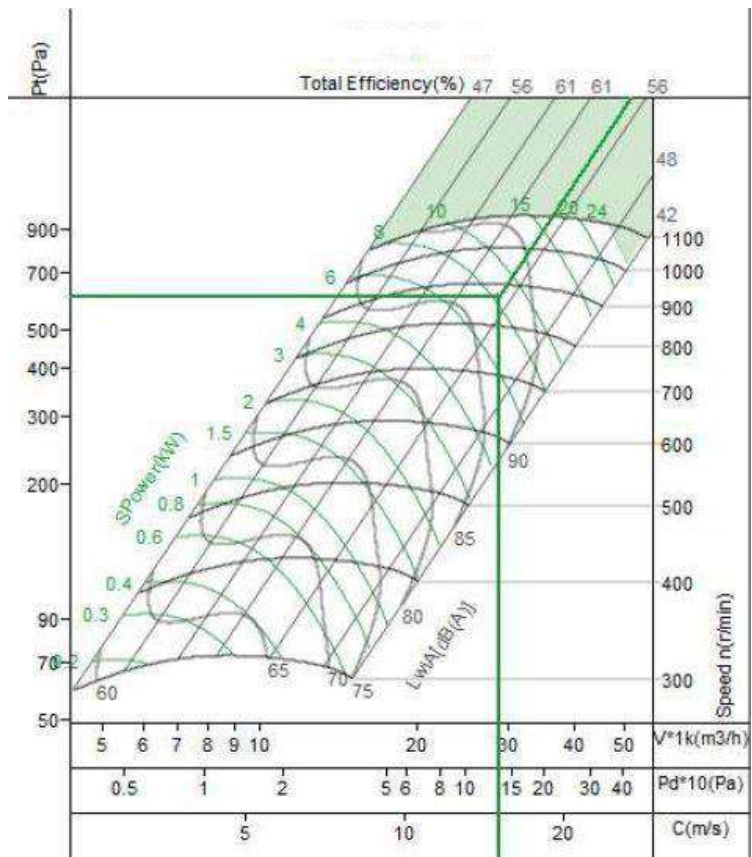

Fan Performance Curve

FWCP 70

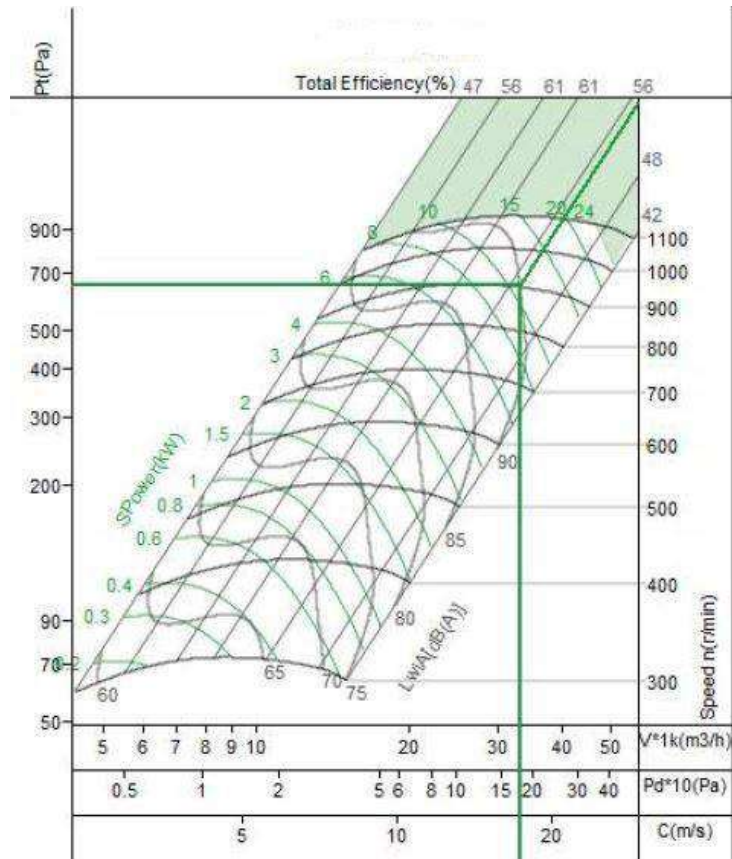

FWCP 80

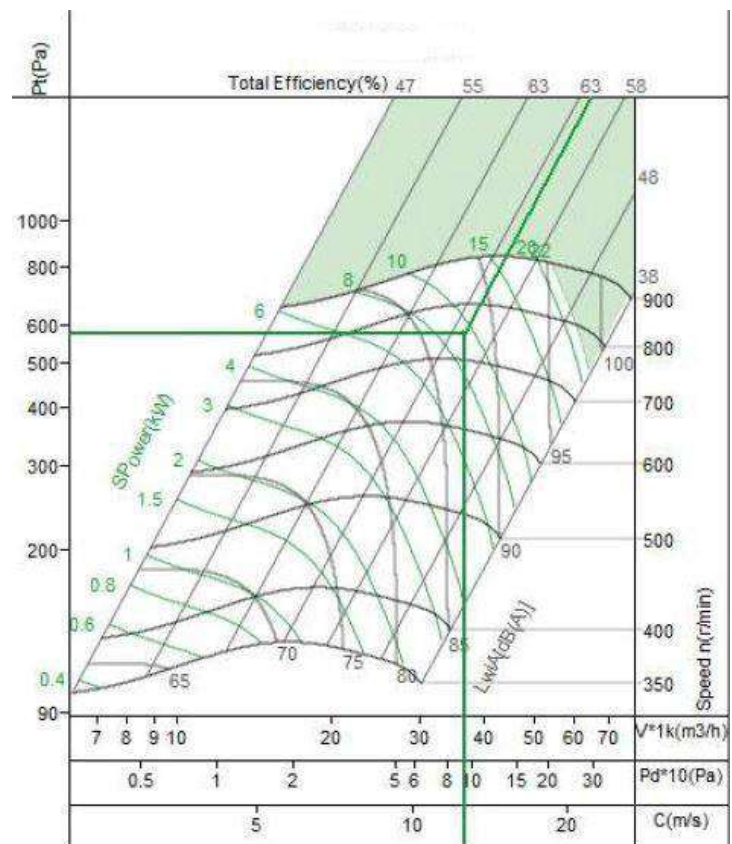

Fan Performance Curve

FWCP 90

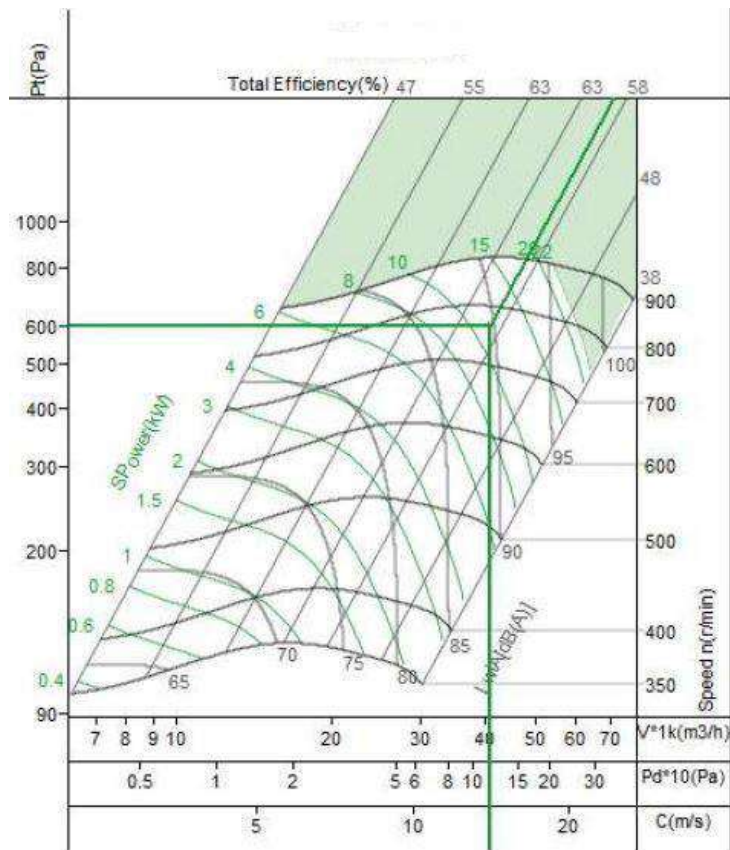

FWCP 100

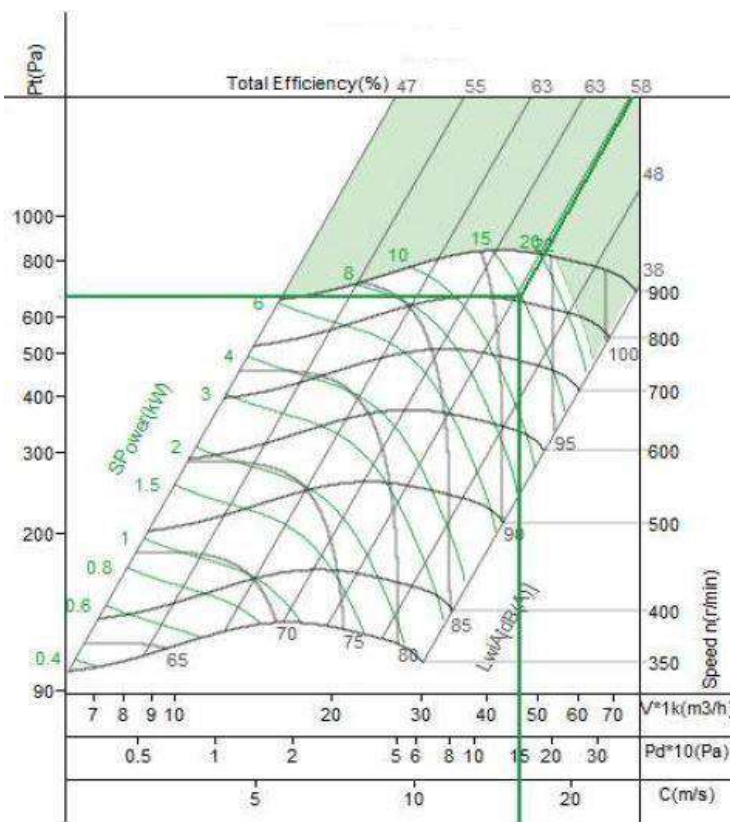

Dimension

Model: FWCP 15 (Single Skin)

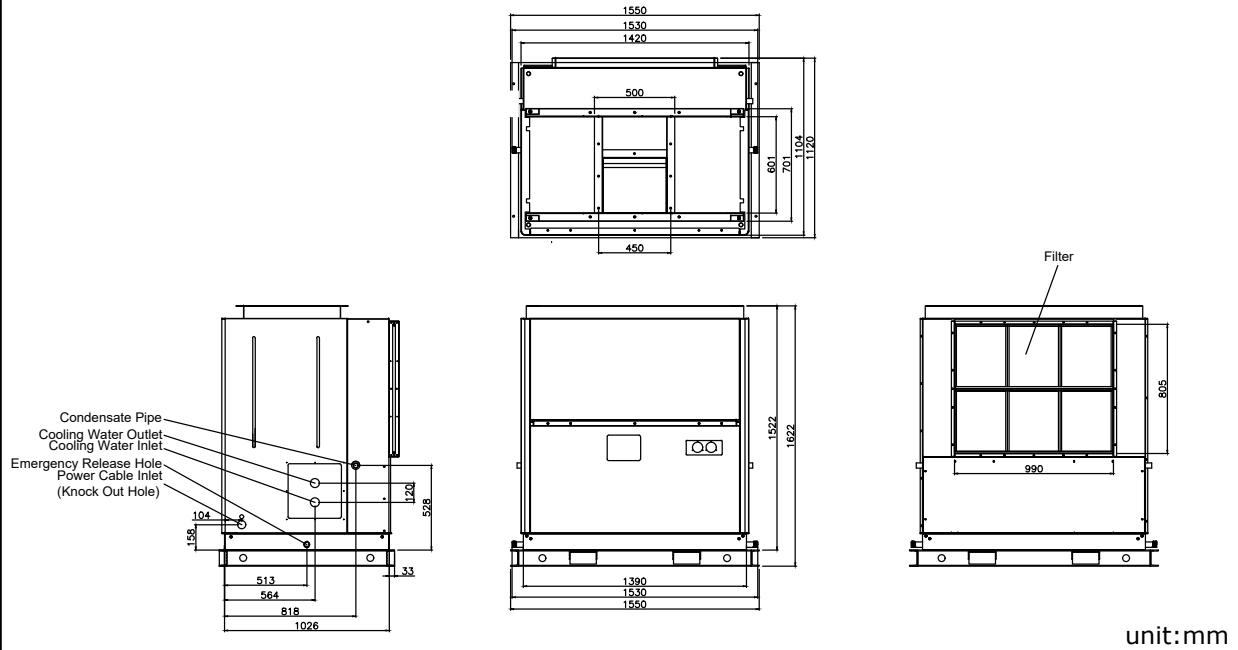

Model: FWCP 20 / 25 / 30 (Single Skin)

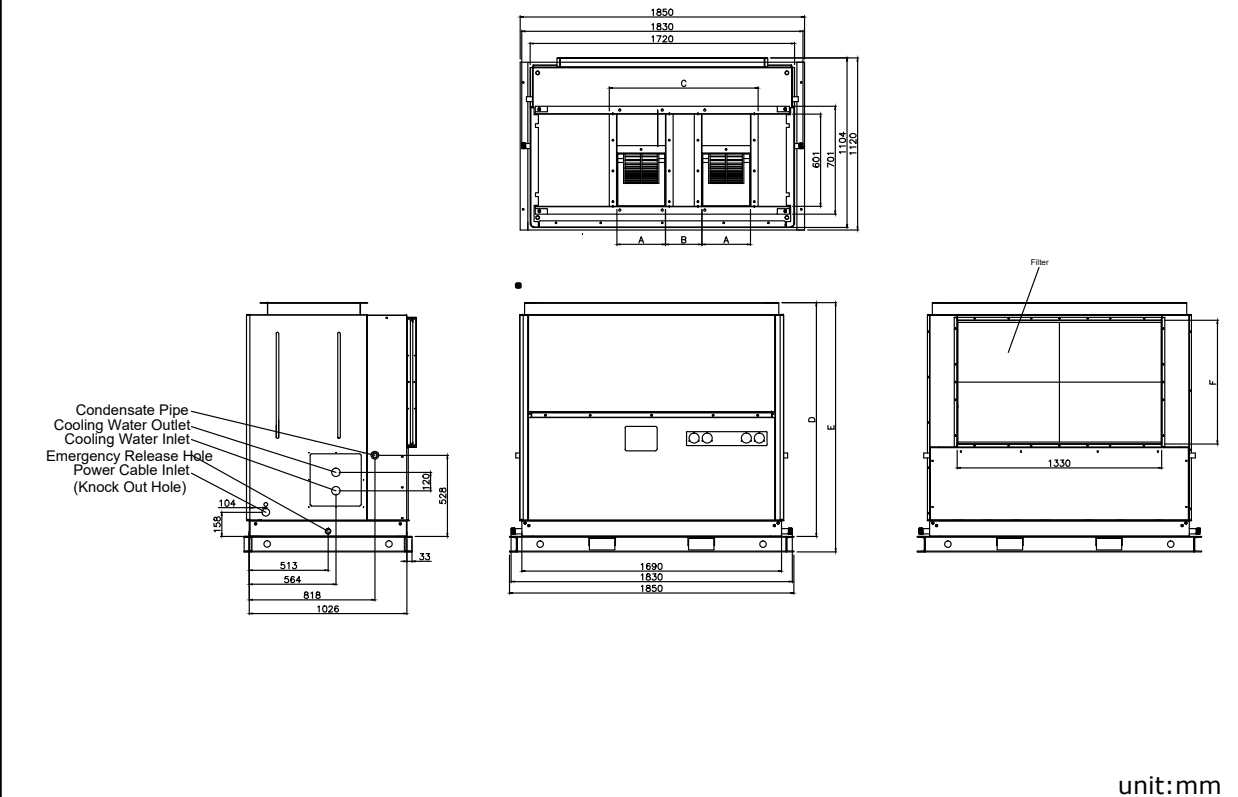

Model: FWCP 35 / 40 (Single Skin)

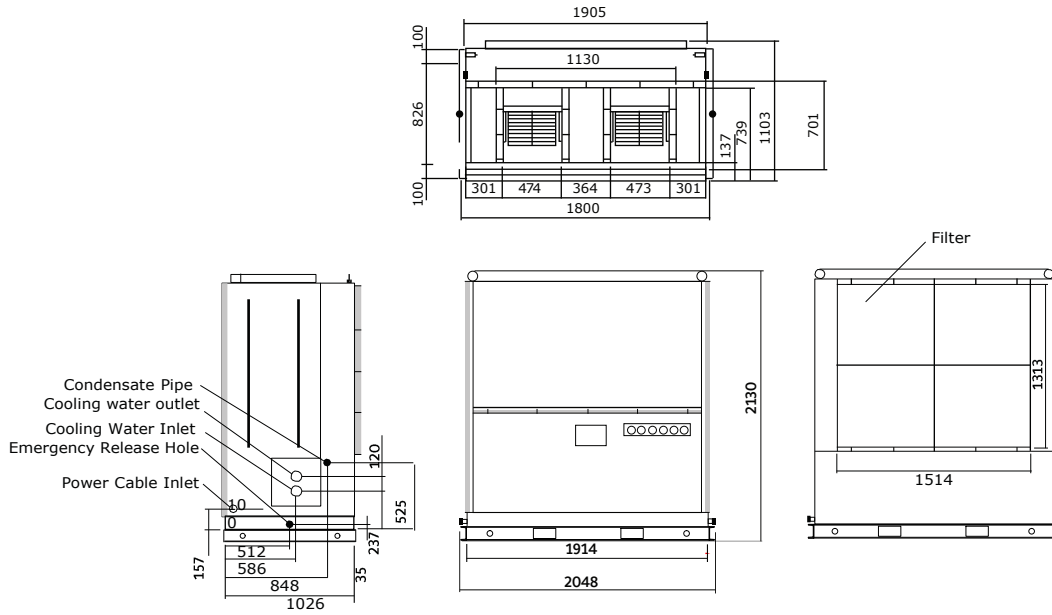

Model: FWCP 45 / 50 / 55 (Single Skin)

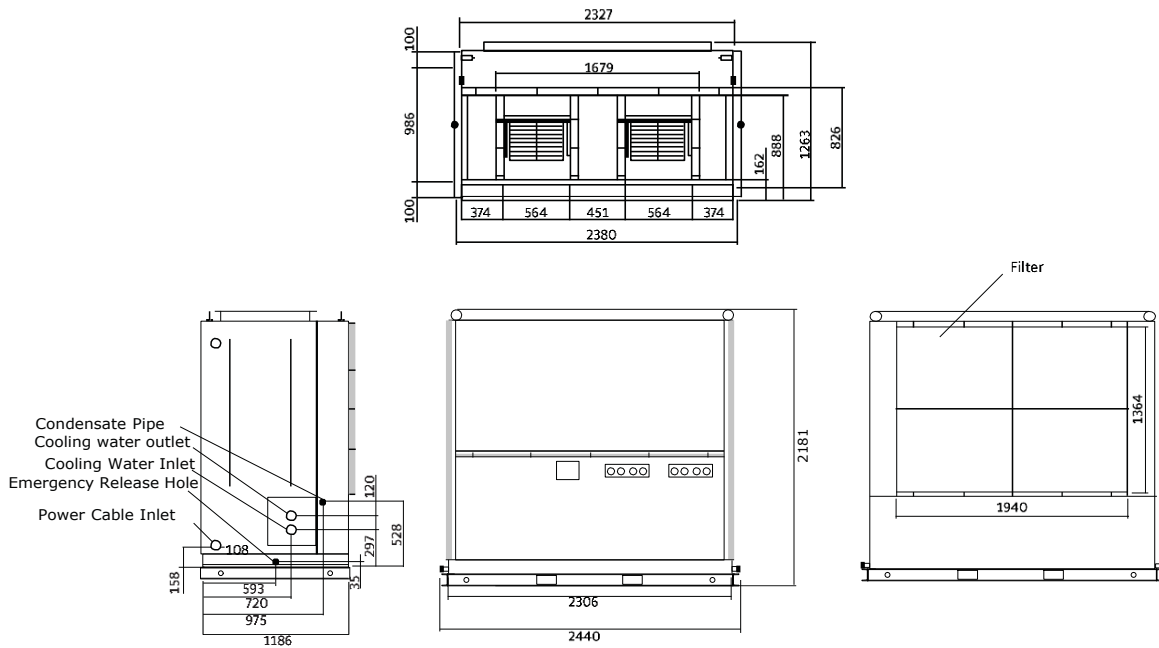

unit:mm

Model: FWCP 60 / 65 / 70 (Single Skin)

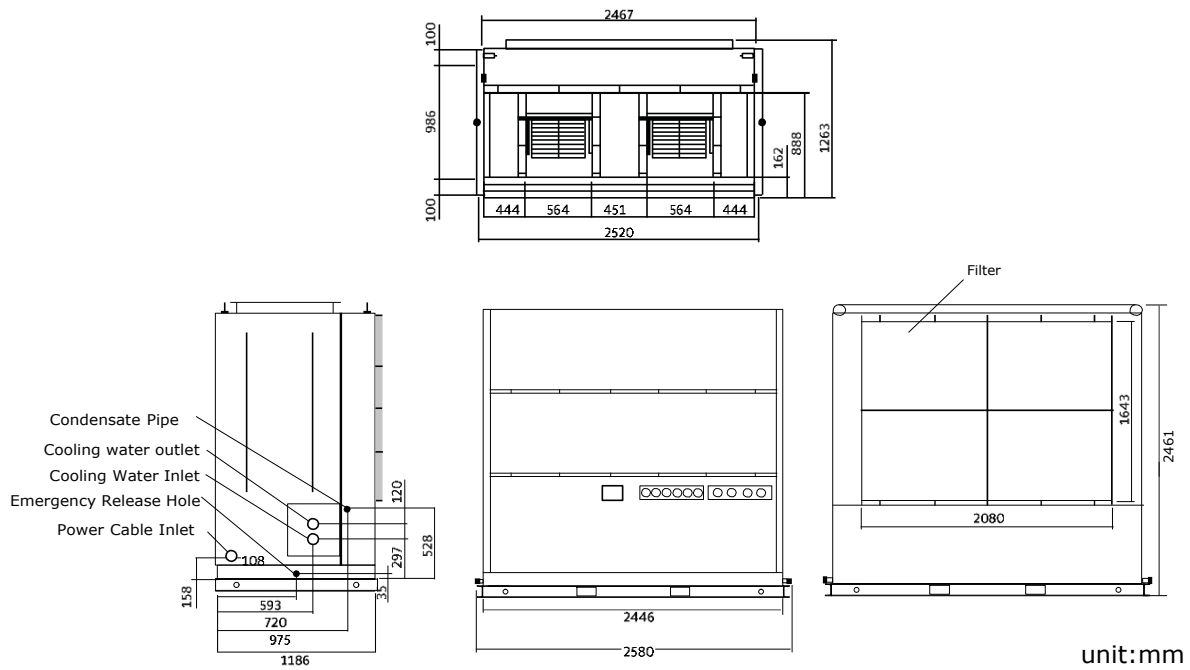

Model: FWCP 80 / 90 (Single Skin)

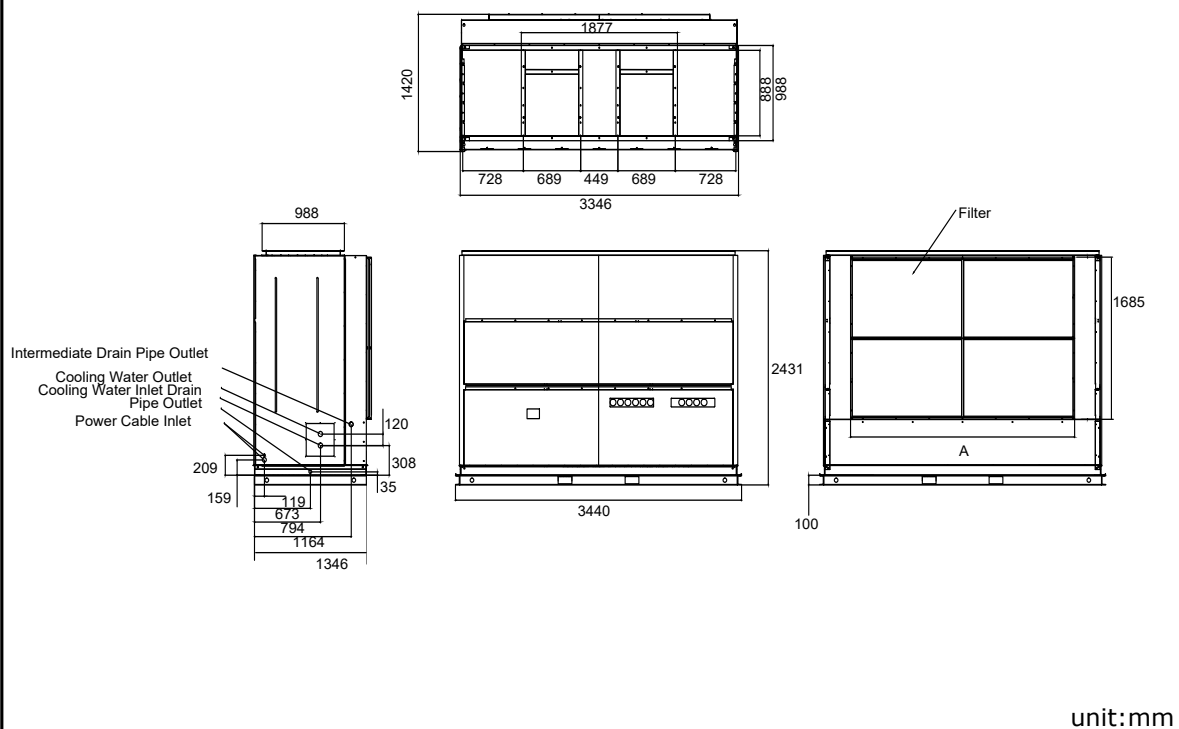

Model: FWCP 100 (Single Skin)

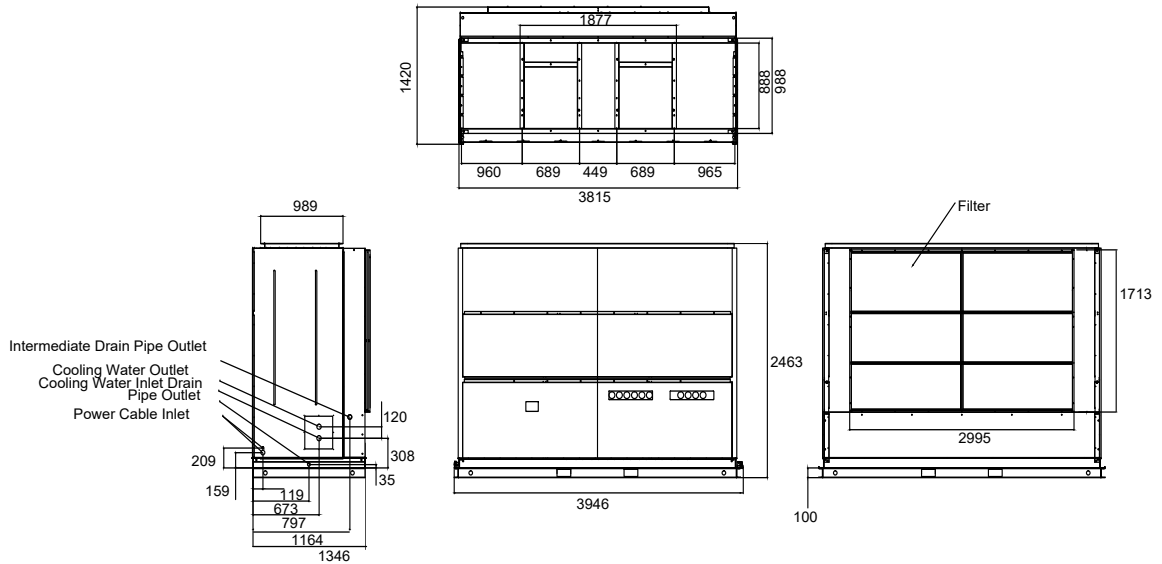

unit:mm

Model: FWCP 15 (Double Skin)

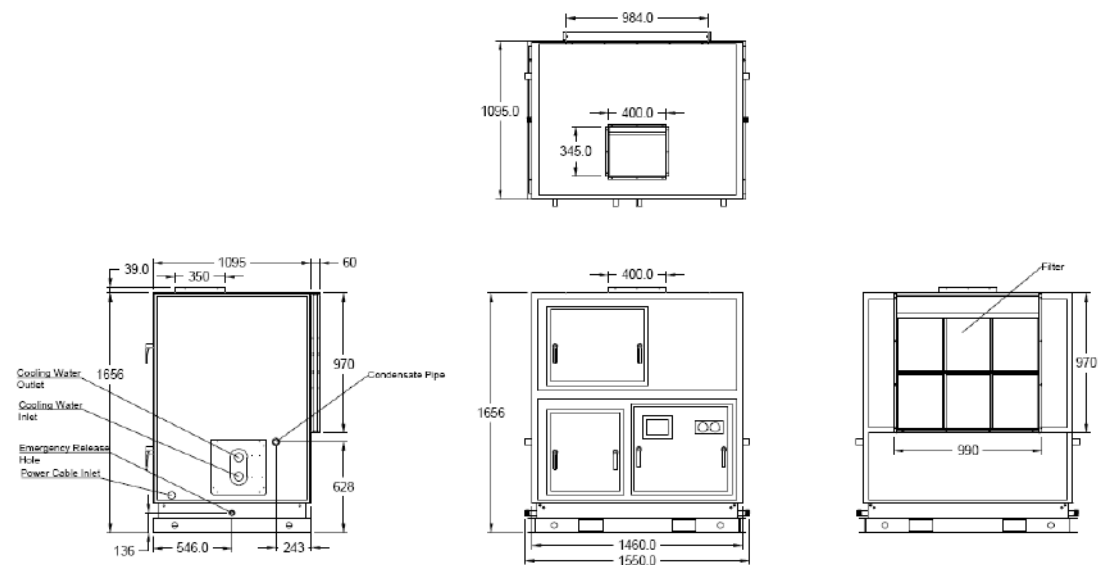

unit:mm

Model: FWCP 30 (Double Skin)

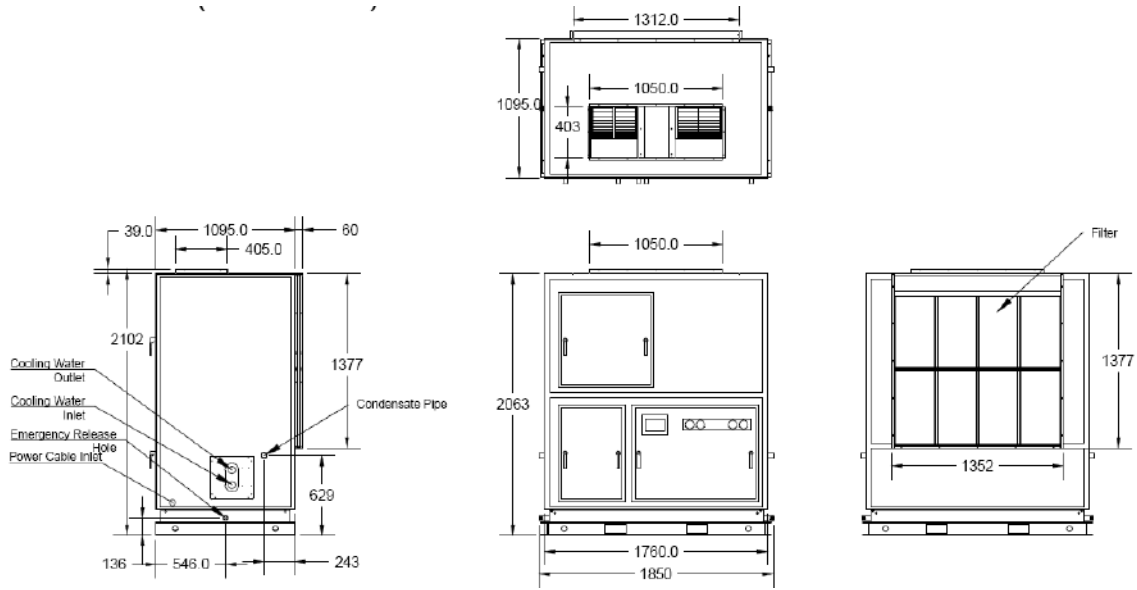

unit:mm

Model: FWCP 35 / 40 (Double Skin)

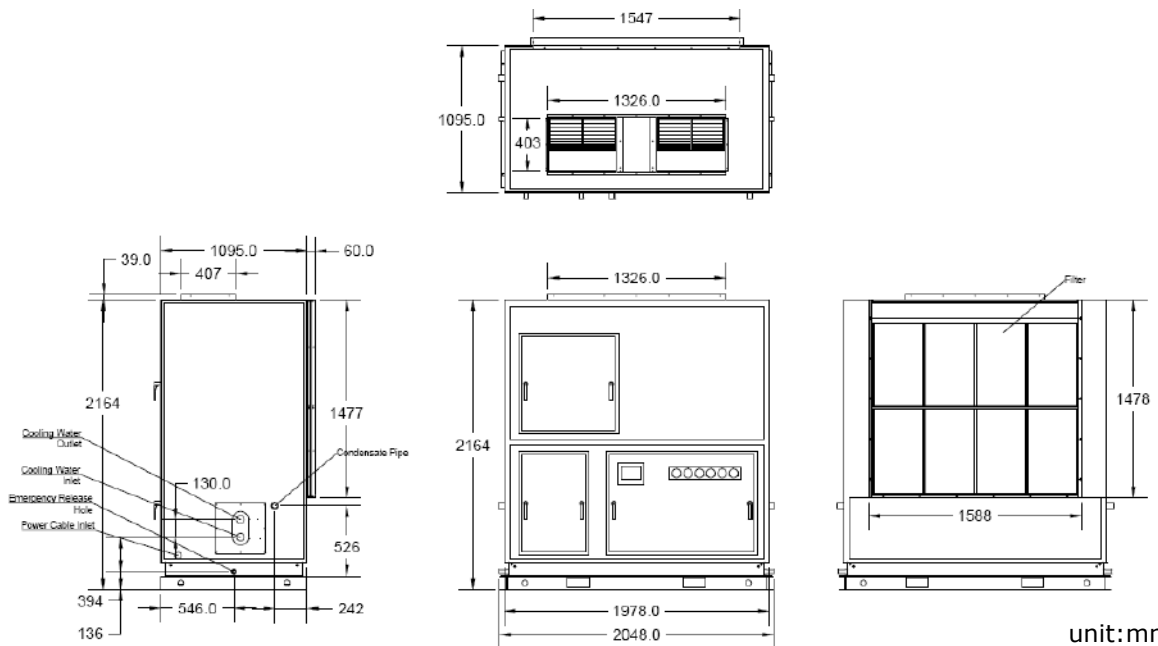

unit:mm

Model: FWCP 45 / 55 (Double Skin)

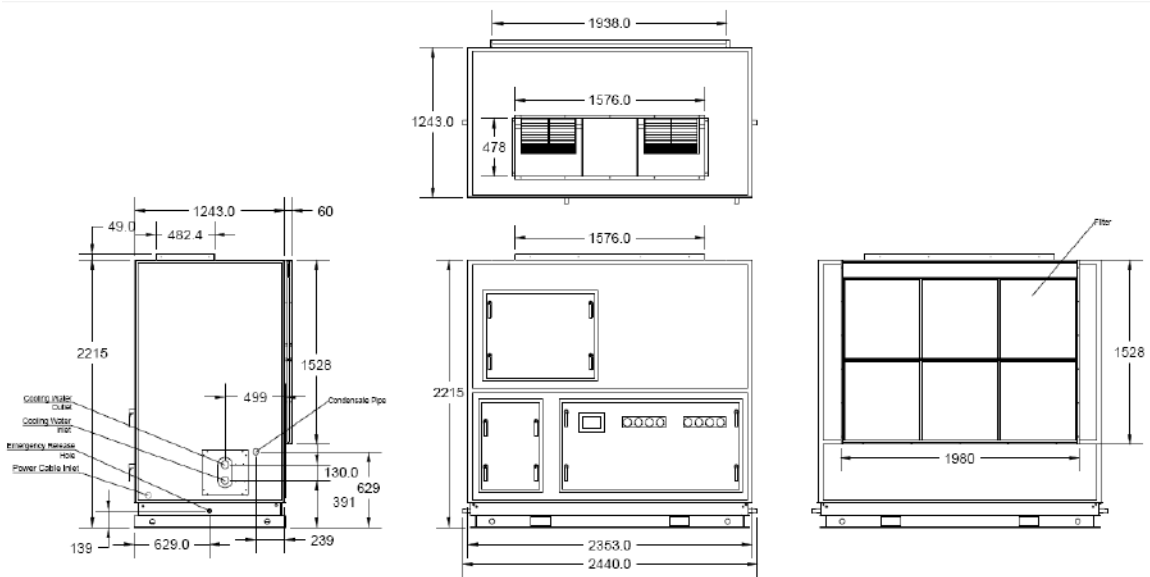

unit:mm

Model: FWCP 60 (Double Skin)

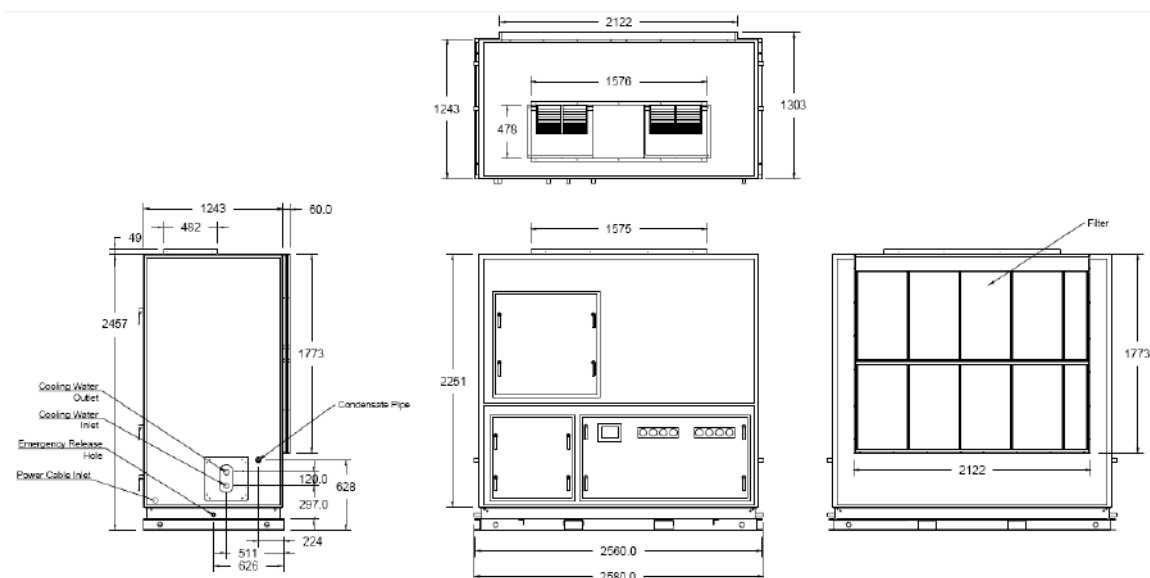

unit:mm

Model: FWCP 65 / 70 (Double Skin)

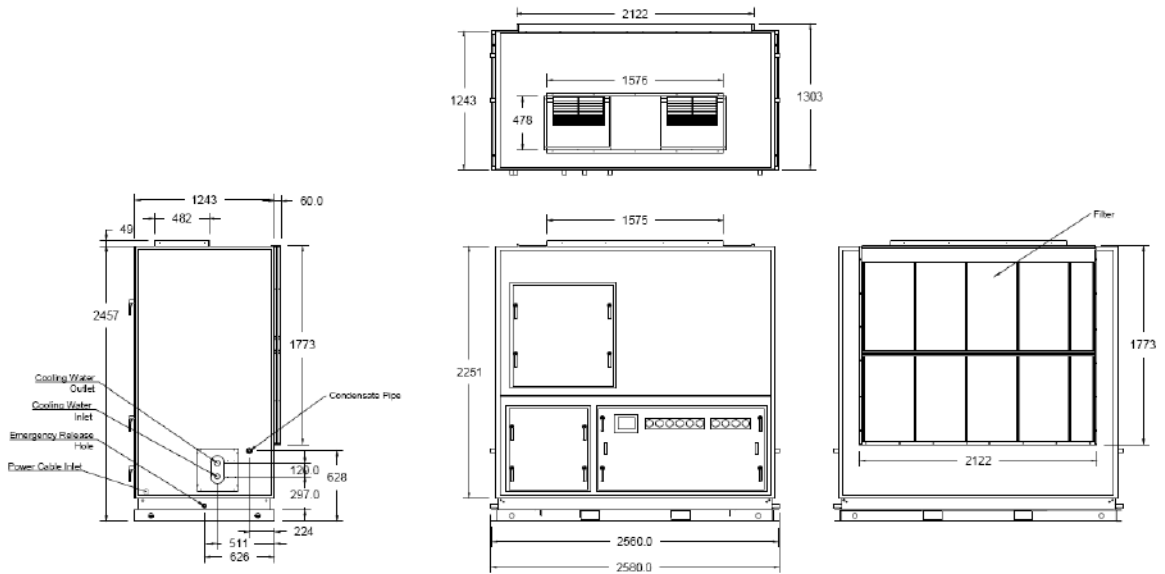

unit:mm

Model: FWCP 80 / 90 (Double Skin)

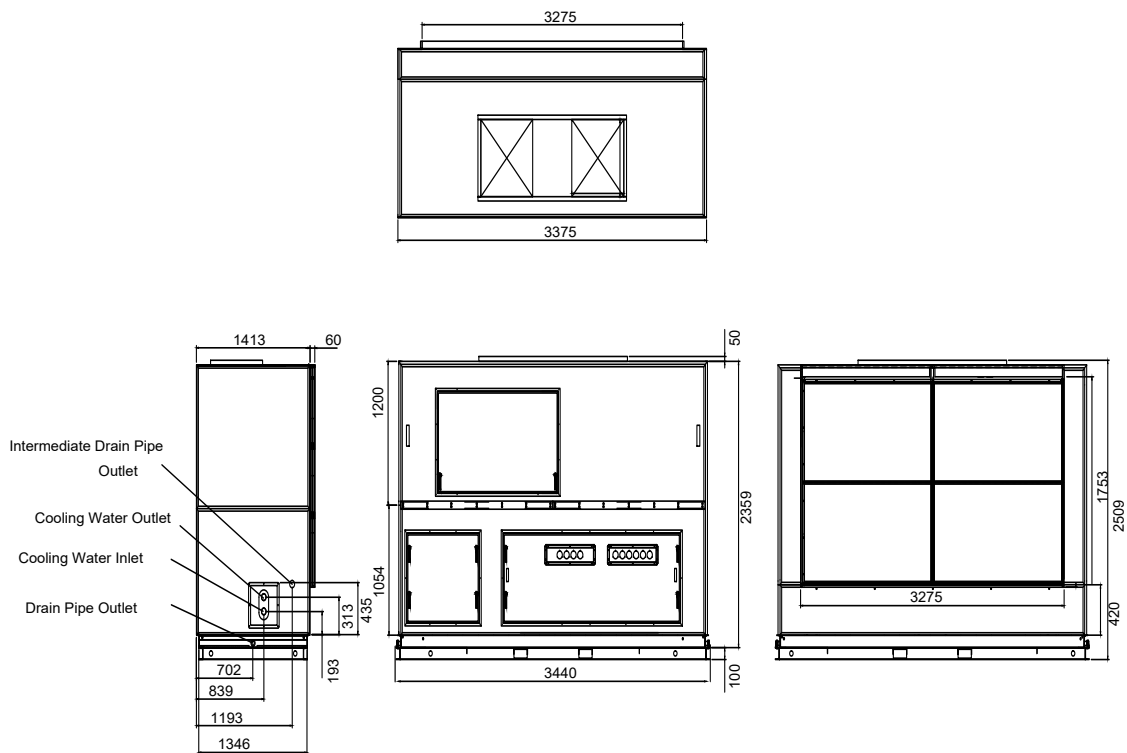

unit:mm

Model: FWCP 100 (Double Skin)

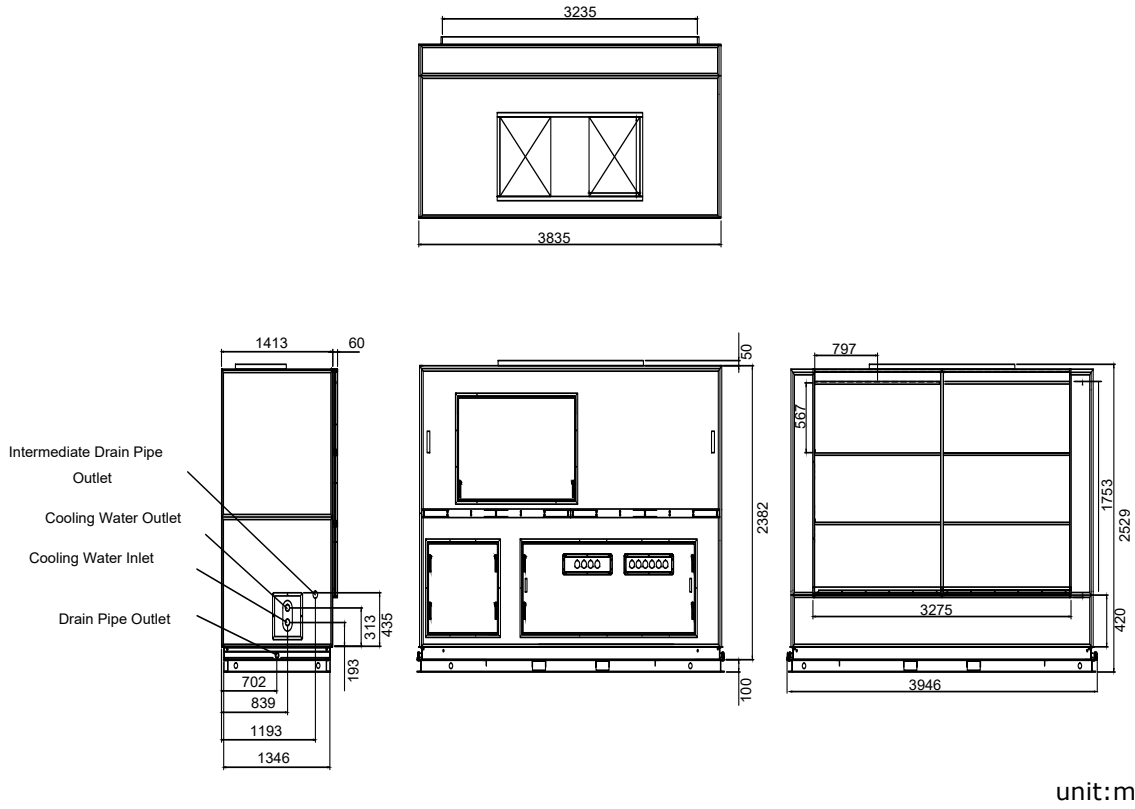

Wiring Diagram

Model: FWCP 15

SUPPLY : 380-415VAC / 3N-PE / 50Hz

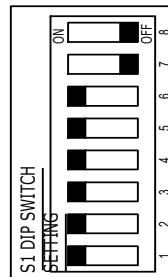
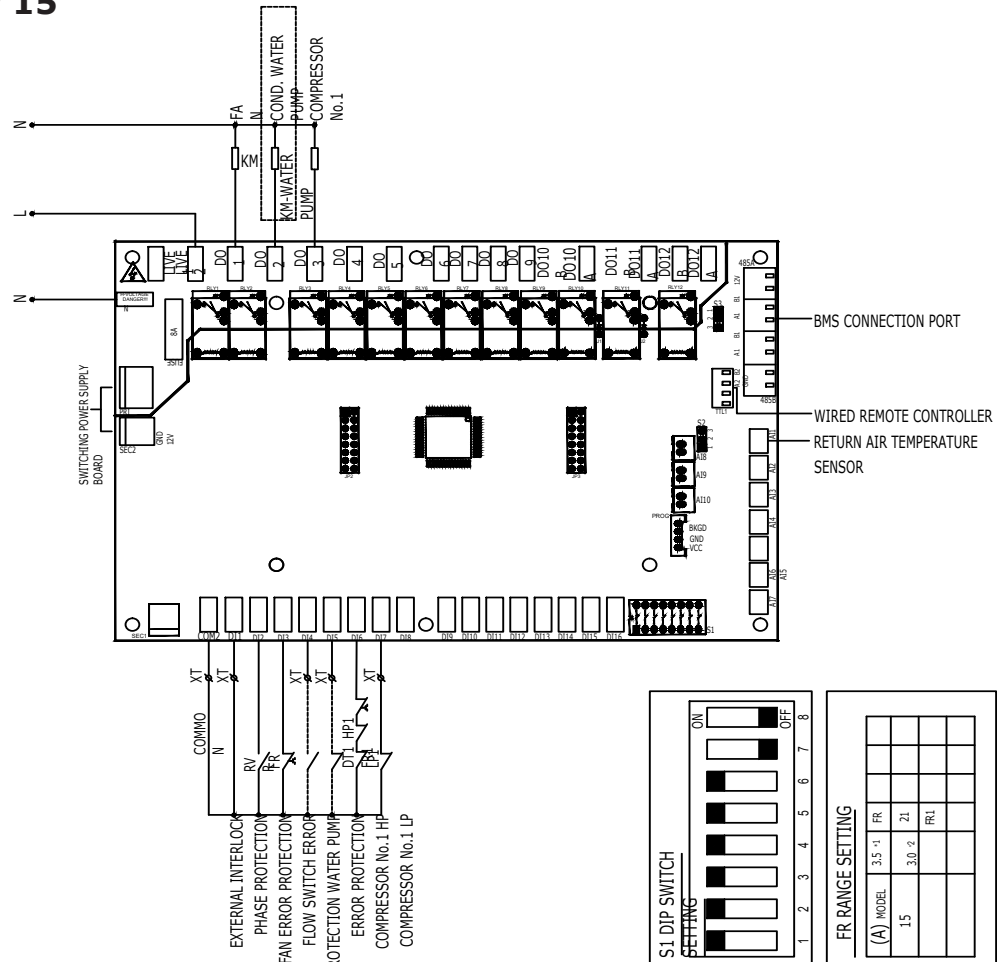
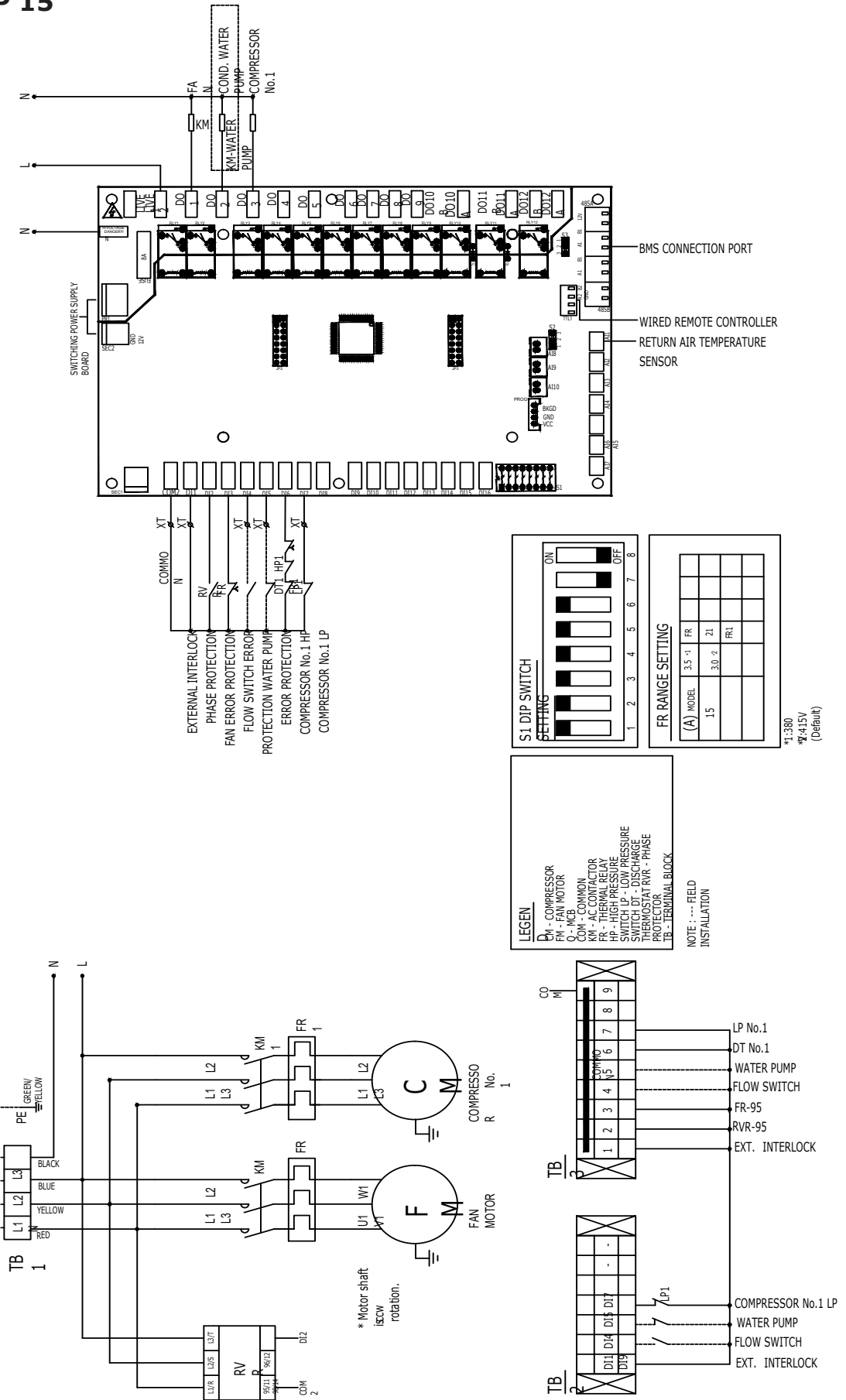

FR RANGE SETTING

(A) MODEL	3.5-1	FR
1.5	3.0-2	21
		FR1

*1.380
*2.415V
(Default)

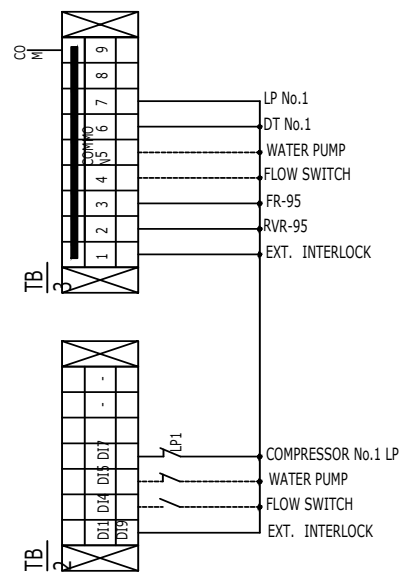
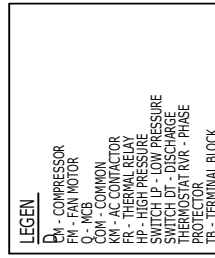

Model: FWCP 20 / 25 / 30

Ver.1.3

SUPPLY : 380-415VAC / 3N-PE / 50Hz

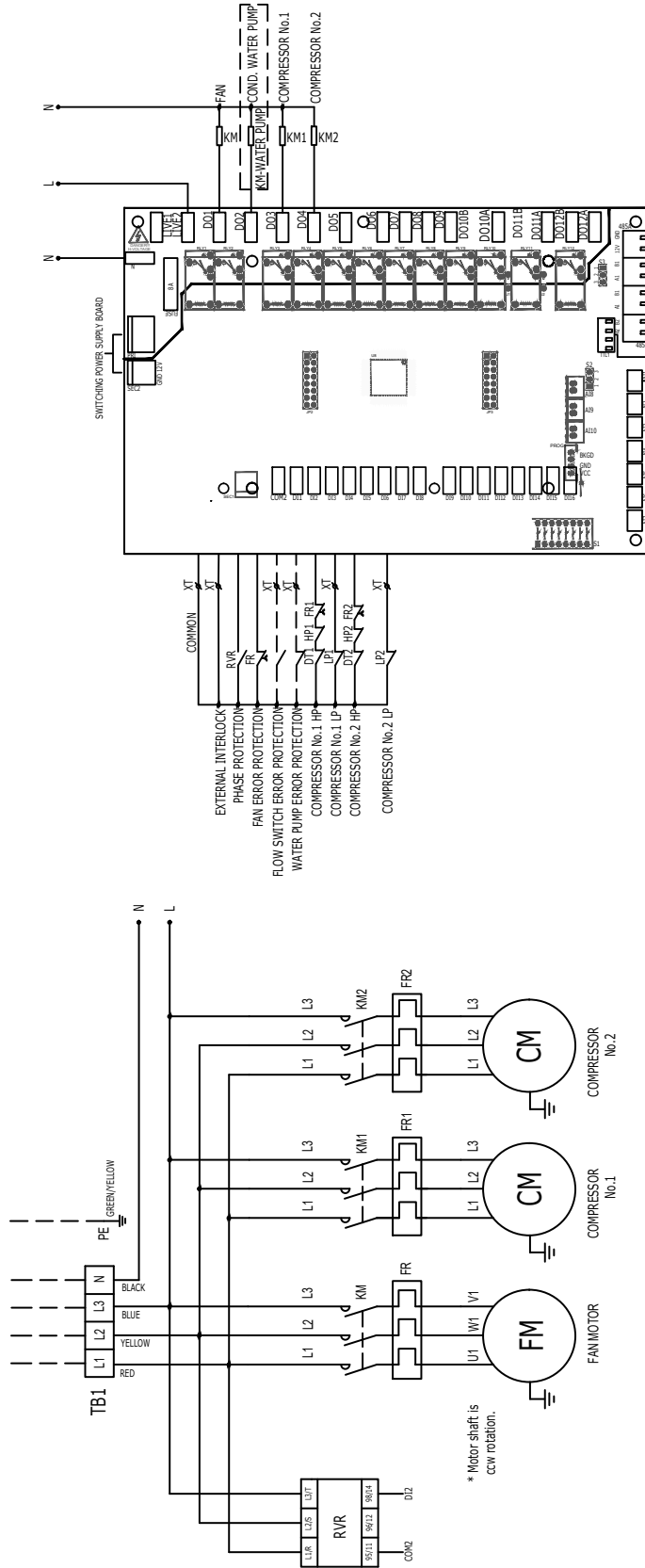

* Motor shaft is ccw rotation.

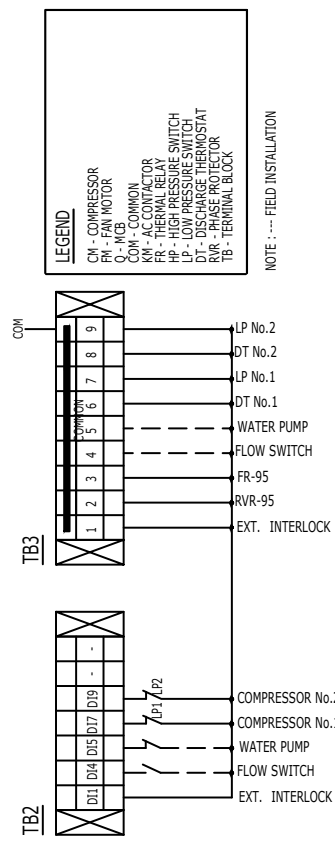

LEGEND

- CM - COMPRESSOR
- FM - FAN MOTOR
- Q - MCB
- COM - COMMON
- KM - CONTACTOR
- HP - HIGH PRESSURE SWITCH
- LP - LOW PRESSURE SWITCH
- DT - DISCHARGE THERMOSTAT
- RVR - PHASE PROTECTOR
- TB - TERMINAL BLOCK

NOTE : --- FIELD INSTALLATION

S1 DIP SWITCH SETTING

FR RANGE SETTING (A)

MODEL	FR	FR2
20	3.5T	1.5
25	6.5T	1.9
30	8.5T	2.1

*1:380W
*2:415V (Default)

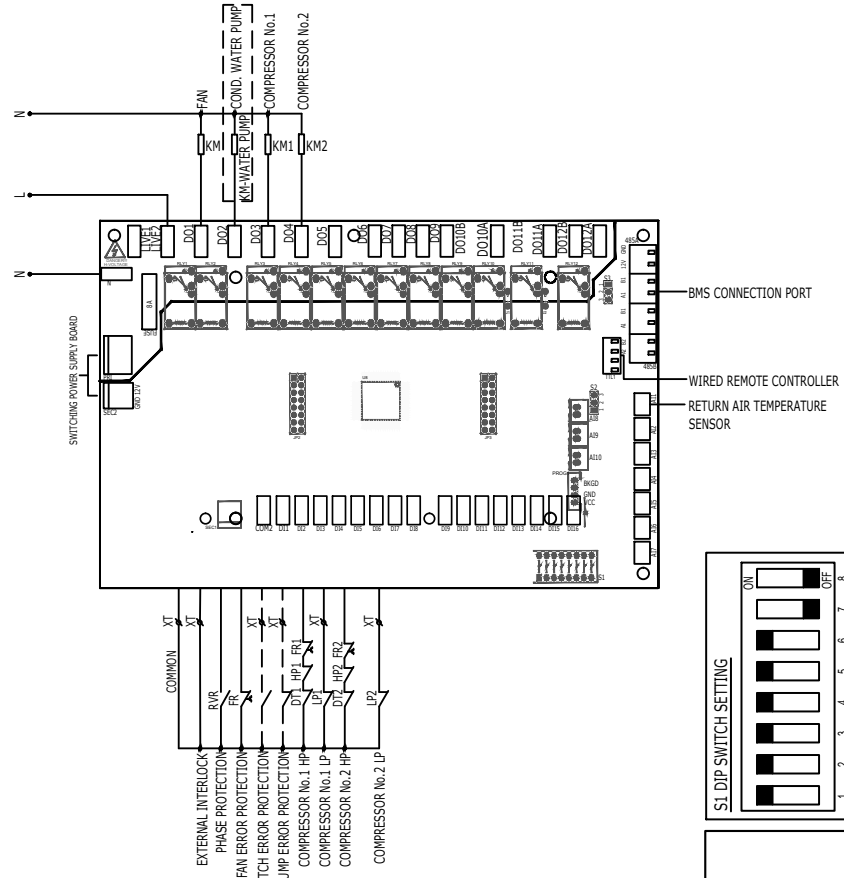

Model: FWCP 35 / 40

Ver.1.3

SUPPLY : 380-415VAC / 3N-PE / 50HZ

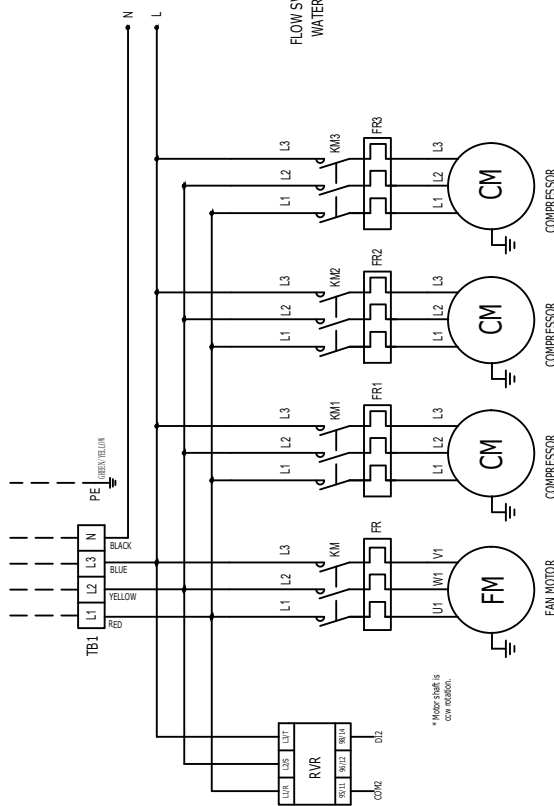

* Motor shaft is
cw rotation.

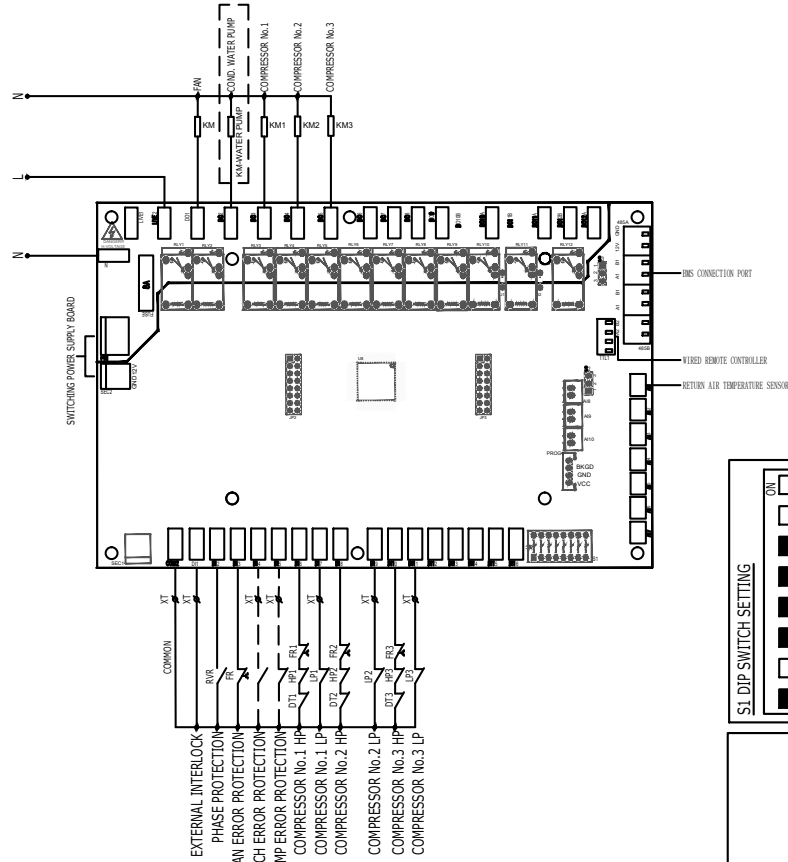

LEGEND

- CM - COMPRESSOR
- FM - FAN MOTOR
- O - MCB
- COM - COMMON
- AL - ALARM
- FR - THERMAL RELAY
- HP - HIGH PRESSURE SWITCH
- LP - LOW PRESSURE SWITCH
- SW - SWITCH
- RVR - PHASE PROTECTOR
- TB - TERMINAL BLOCK

NOTE : --- FIELD INSTALLATION

S1 DIP SWITCH SETTING

FR RANGE SETTING (A)

MODEL	FR1	FR2	FR3
35	11.5~12	19	19
40	11.5~12	19	19

*1-380V
*2-415V (Default)

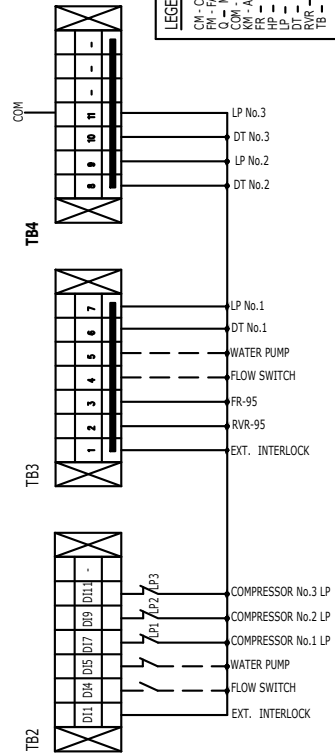

Model: FWCP 45 / 50 / 55 / 60

Ver.1.3

SUPPLY : 380-415VAC / 3N-PE / 50Hz

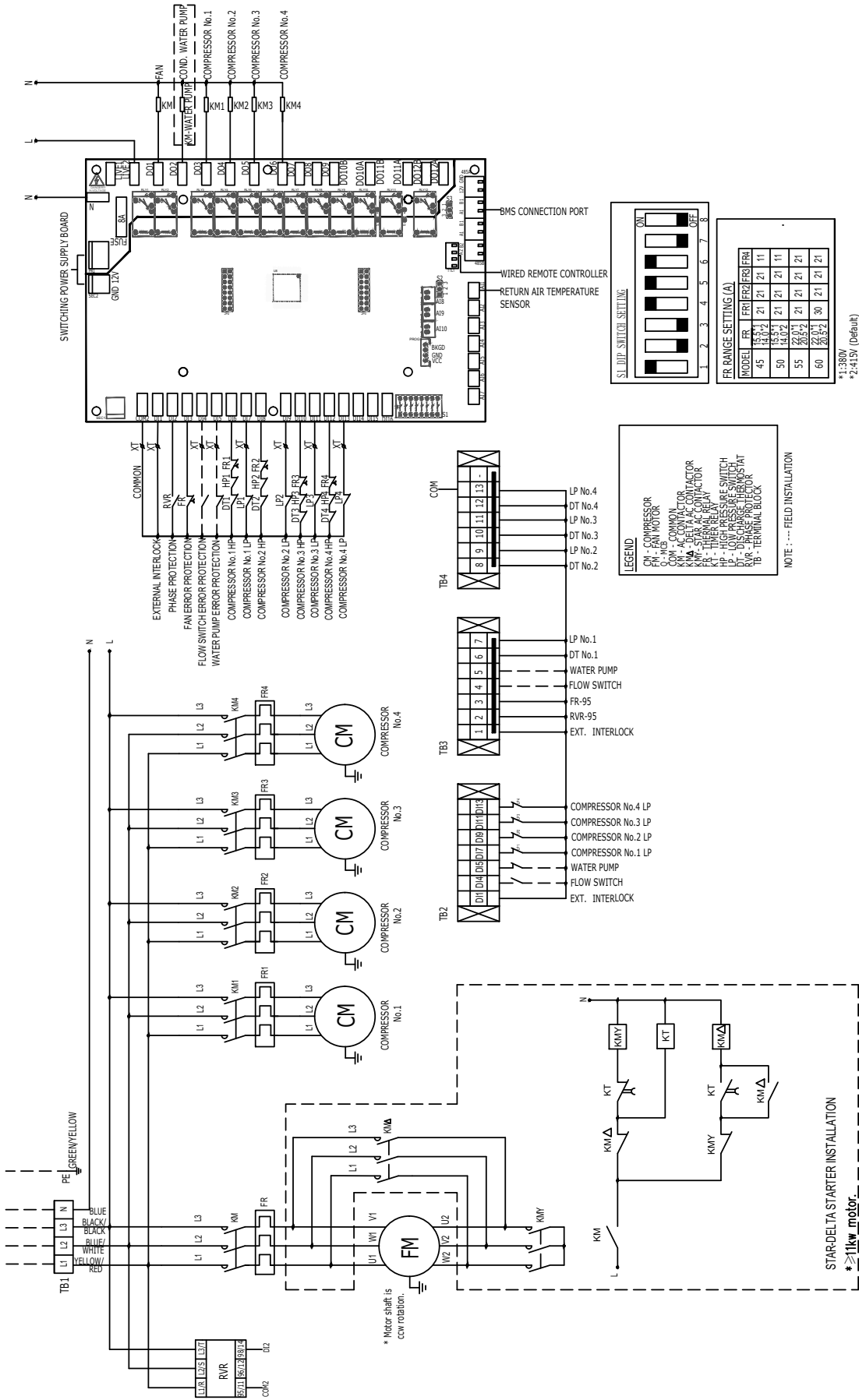

* Motor shaft is ccw rotation

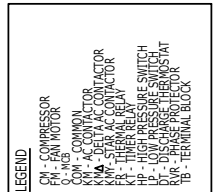
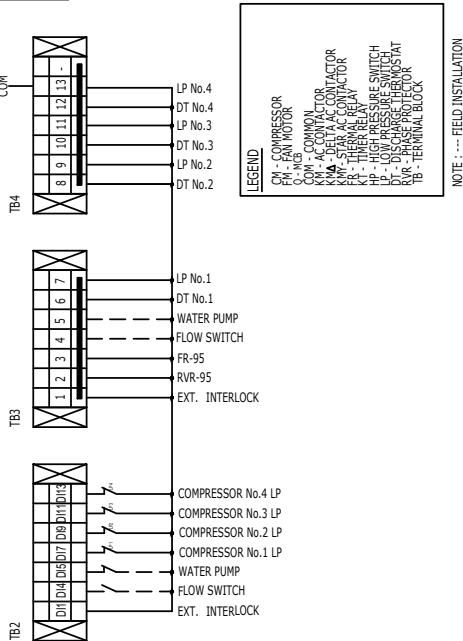

NOTE : --- FIELD INSTALLATION

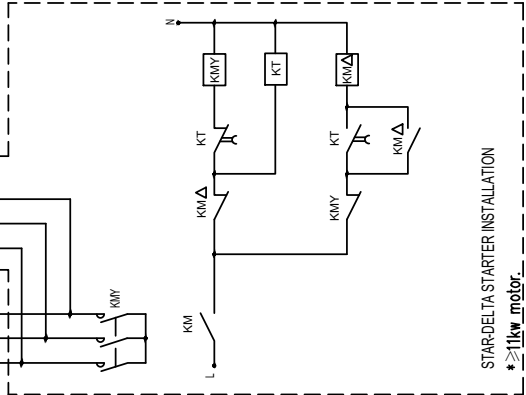
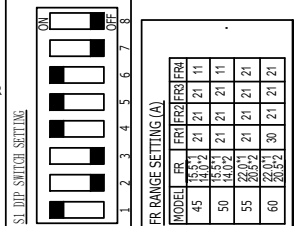

Model: FWCP 65 / 70 / 80 / 90

Ver:1.3

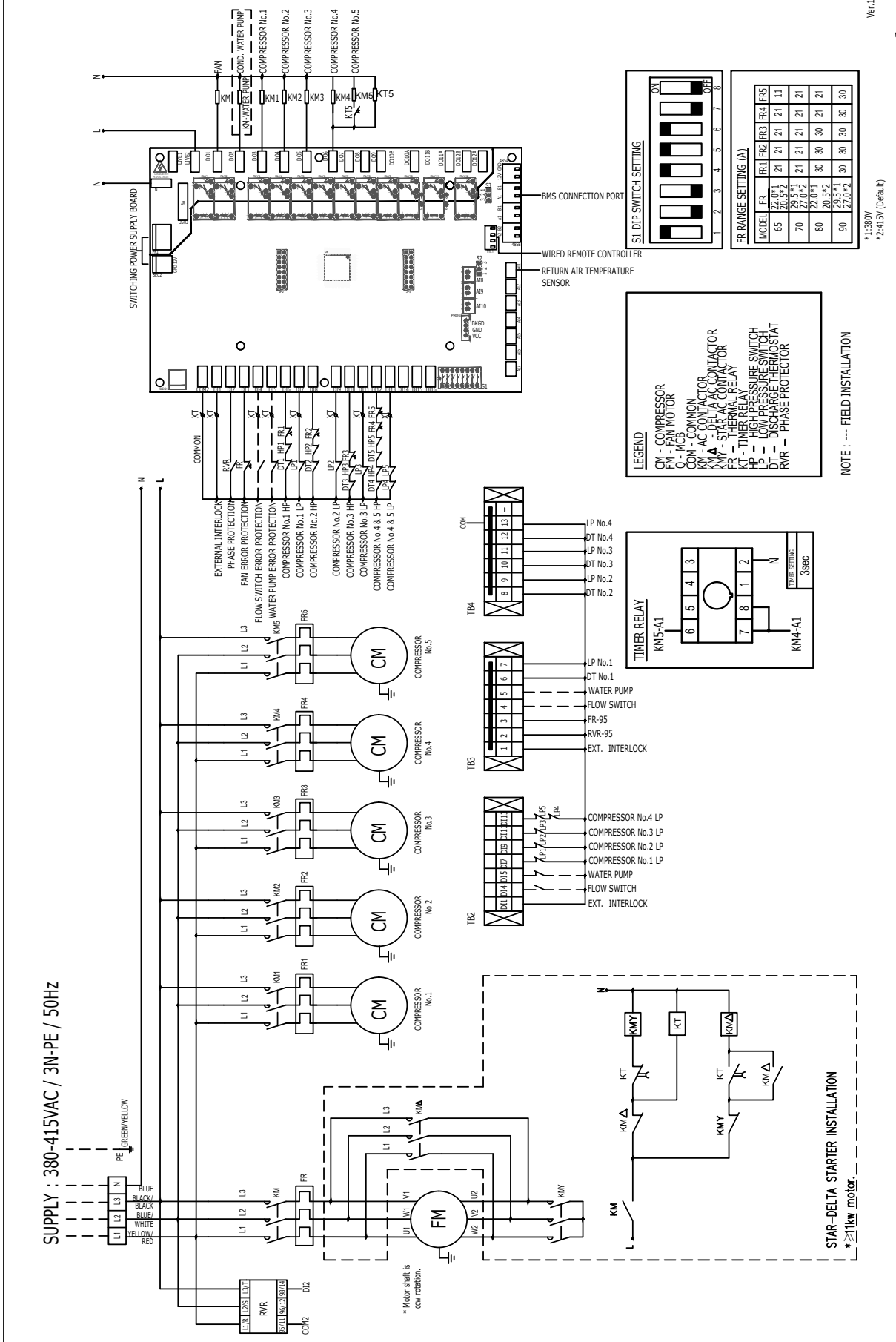

S1 DIP SWITCH SETTING

1	2	3	4	5	6	7	8
ON	ON	ON	ON	ON	ON	ON	ON

FR RANGE SETTINGS (A)

MODEL	FR1	FR2	FR3	FR4	FR5
65	22.0*1	21	21	21	21
70	29.5*1	21	21	21	21
80	27.0*2	30	30	30	21
90	20.8*1	30	30	30	30
	27.0*2	30	30	30	30

*1:380V
*2:415V (default)

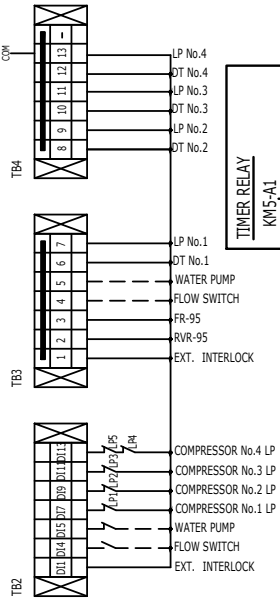
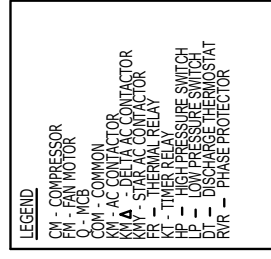

Model: FWCP 100

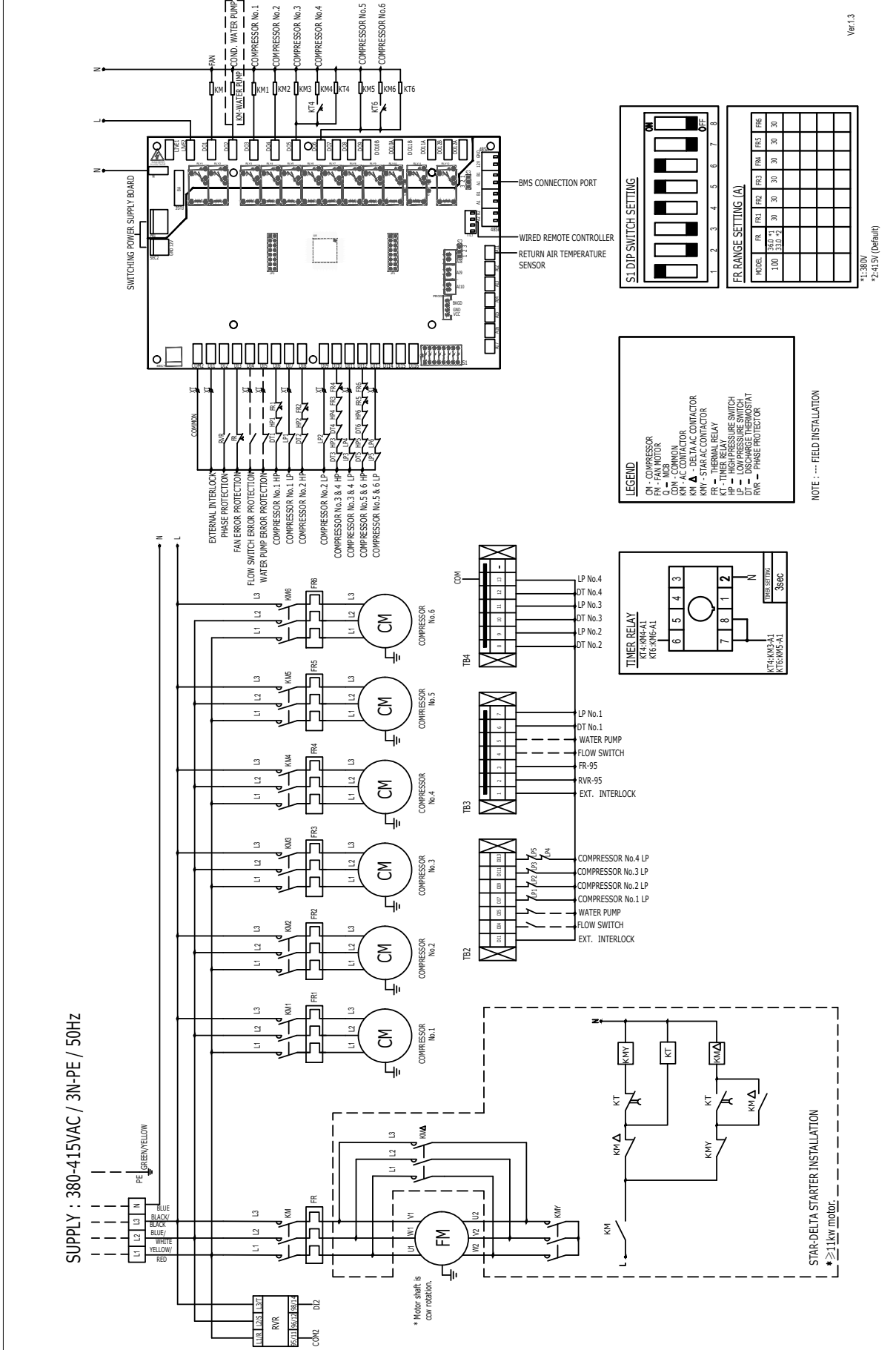

SUPPLY : 380-415VAC / 3N-PE / 50HZ

* Motor shaft is ccw rotation.

STAR-DELTA STARTER INSTALLATION
* ≥ 1.1kw motor.

LEGEND

- CM - COMPRESSOR
- FM - FAN MOTOR
- KT - THERMAL RELAY
- KT5 - KMG-A1
- KT6 - KM5-A1
- KM - STAR-DELTA CONTACTOR
- KMY - DELTA A.C CONTACTOR
- FR - THERMAL RELAY
- FR95 - FLOW SWITCH
- LP - LOW PRESSURE SWITCH
- DT - DISCHARGE THERMOSTAT
- RVR - PHASE PROTECTOR

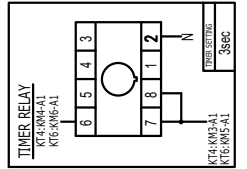

SL DIP SWITCH SETTING

FR RANGE SETTING (A)

MODEL	FR1	FR2	FR3	FR4	FR5	FR6
100	130.1	30	30	30	30	30
330.2						

NOTE : ... : FIELD INSTALLATION

Ver.1.3

*1:380V
*2:415V (Default)

Installation

System Connection Diagram

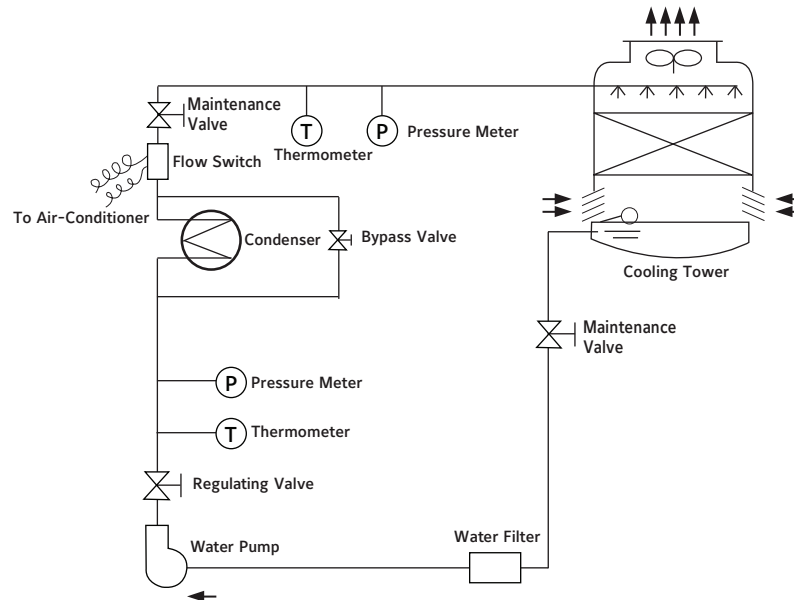

1. Location and Clearance

- Unit must be installed on a flat concrete base and the base must be able to withstand the weight of the unit.
- Standard unit is not meant to be installed outdoors and the location of installation must be free from corrosives and explosives environment.
- Sufficient space must be allocated for water drainage, ventilation and service.
- The unit and duct work must be isolated from wall or ceiling to prevent direct transmission of vibration noise to the air-conditioned space. Special consideration should be made to choose the location of installation if noise is of main concern and sound attenuation might be needed for duct work and room.

Installation clearance

FWCP 15~100

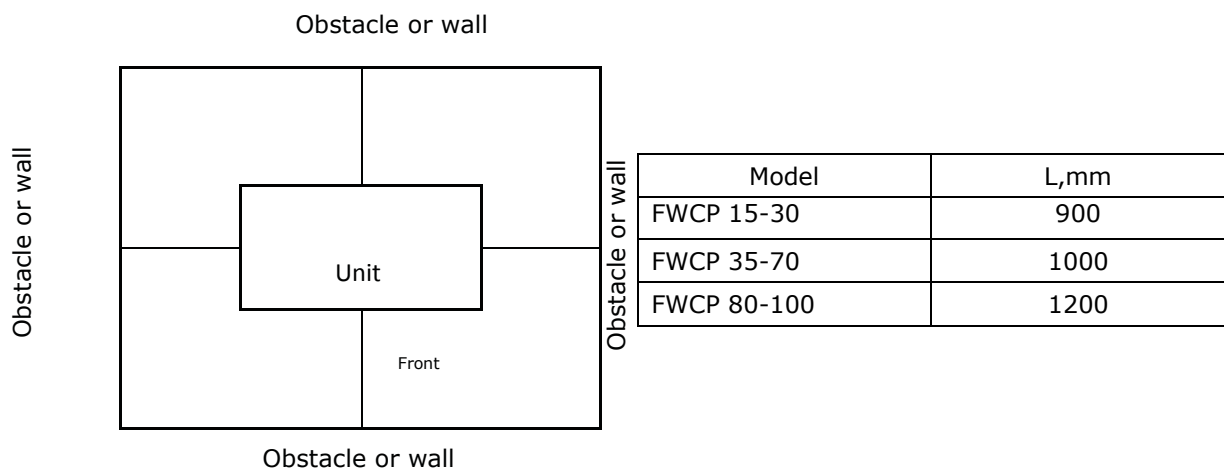

2. Water System Installation

Water pipes system must adhere to local codes and regulations. Pipe works must avoid unnecessary bends and offset (up and down). In order to prevent cooling water temperature from becoming too low, it is advisable to install temperature-sensing switch that will stop the fan of cooling tower when cooling water temperature drops below 27°C. Recommendation for cooling water installation is as following:

- At the highest point of pipe work, install a manual or automatic air vent.
- Maintain proper pressure of water (to install modulating valve or expansion tank).
- Install pressure gauge and thermometer to ease maintenance work.
- Install strainer before water pump to filter foreign particles in water.
- Ensure the water inlet and outlet pipes from unit are connected correctly to the relevant pipe.
- There must be make-up water for cooling tower as the evaporation of water will reduce the water in circulation.

CAUTION:

MAXIMUM WORKING PRESSURE (WATER) FOR SHELL & TUBE CONDENSER IS 145PSI

Condensate water:

- There are 2 standard ways to install condensate water pipe:
 - From the drain pan in between and which separates the evaporator and condenser.
 - From the secondary drain pan at the bottom panel of the unit.
- A gradient of 5° should be maintained for condensate water pipe.
- A U-bend must be installed to avoid back flow of condensate water and to prevent inflow of odor from drainage pipe.

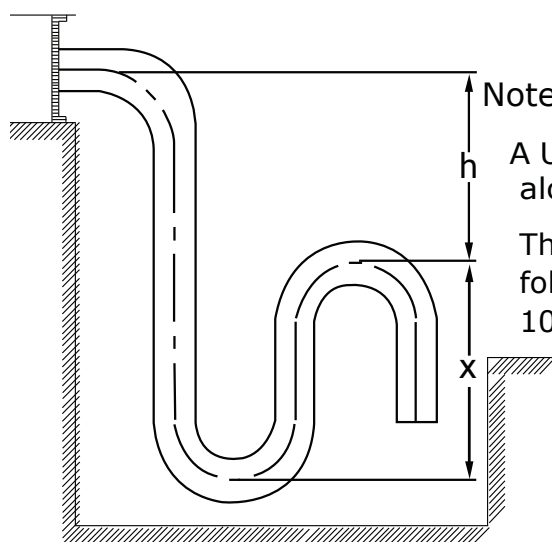

Note:

A U-bend must be installed along the drain pipe.

The recommendation is as following: $50\text{mm} < h < 100\text{mm}$ and $X > h/2$

3. Installation Precautions

- To reduce pump's lost suction pressure, pump must be installed near to the cooling tower to keep the suction pipe short.
- Valves must be installed at necessary points to ease maintenance job. Recommended valves are gate valves, globe valves and ball valves.
- To reduce noise generated and transmitted from pump vibration, it is recommended to install flexible pipes before and after pump.
- Pressure gauge must be installed at location which is visible and easily accessible. If the pump is pumping water from low-level tank, a vacuum gauge should be installed at the pump suction instead.
- A water flow switch should be installed to protect air conditioner if there is unexpected interruption of cooling water circulation.
- It is recommended to install a "bypass" 3-way valve to modulate the cooling water flowing through the condenser when there is change in load condition or ambient temperature. The valve should be set to maintain the lowest condenser leaving water temperature of 18.3°C.

4. Cooling Tower

Parameters needed to select a cooling tower are as follows:

- Cooling water flow rate
- Ambient dry bulb temperature
- Cooling water outlet temperature
- Cooling water inlet temperature
- Total capacity
- Power supply
- Quality of local water supply

Cooling tower installation

Parameters needed to select a cooling tower are as follows:

Site for installation of cooling tower must be designed to take the total weight of cooling tower and water. Some precautions of installation for cooling tower are as follows:

- Location of installation must avoid direct sun light (if possible) and the surrounding area must be well ventilated and free from pollution. It is not recommended to install the cooling tower near kitchen where there is oil and high temperatures.
- Due to the water evaporation in the cooling tower, make-up water must be provided to cater for the water lost. The make-up water is usually 1 ~ 3% of total circulation water.
- It is very important to maintain the water quality of cooling water. The most practical and effective way is to use chemical cleaning, i.e., periodically add in chemicals and water softener to treat the water. pH of circulation water is required to be from 6.0 ~ 8.0, dissolved solid ≤ 5.0 mg/liter, iron content ≤ 0.3 mg/liter, water hardness $\text{CaCO}_3 \leq 50$ ppm.

Air duct connection

Supply air — For standard FWCP unit, there is a built-in flange to ease the duct connection. It is recommended that the first elbow of air duct after the discharge must be at least 3 times the fan wheel diameter (see table: Length of Supply Air Duct). See AMCA 210 "Fan and System" for design details.

Return air — Return air for FWCP is of "Free Return". Thus, plant room air return will be the default design.

Insulation — All air ducts must be properly insulated to prevent heat loss and condensation.

5. Precautions For Fan Motor Installation

The speed of fan depends on air flow, internal static pressure of unit and external static pressure. To ensure the proper operation of fan, the following needs to be considered:

- The pulley of motor and fan must be aligned.
- Belt tension must be optimal because belt with too much or too little tension will cause the power transmission to be ineffective and produce excessive noise.

Before leaving factory, the alignment and tension has been set and tested. Upon 1 week after commissioning of the unit, these 2 factors need to be rechecked and adjusted if necessary. It is recommended to examine the pulley alignment and belt tension once every 2 months and the test result should be within the recommended range.

The proposed method to check the alignment and belt tension is as follows:

- **Pulley alignment**

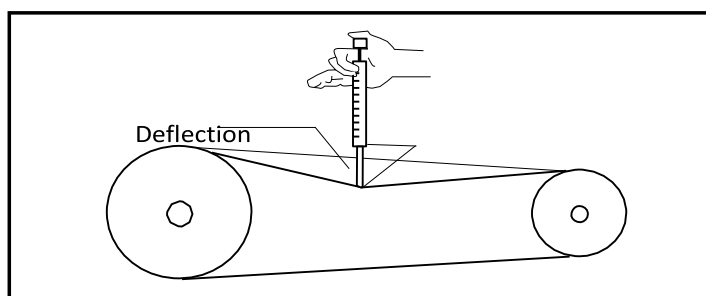

- **Belt tension: use belt tension meter to check the tension**

When the deflection = Total belt length / 64, read the force exerted from the belt tension meter. The recommended force is in below table and for new belt, it is recommended to use the value close to maximum value. Prior to first operation, it is advisable to double check the belt tension so that it is within operating range.

Belt Cross Section Model	Smaller Pulley Range (inch)	Force (lb.-f)	
		Minimum	Maximum
A	3.0-3.6	1-1/2	2-1/4
	3.8-4.8		
	5.0-7.0		
B	3.4-4.2	3-1/2	5-1/4
	4.4-5.6		
	5.8-8.6		
C	7.0-9.4	6-1/2	9-3/4
	9.6-16.0		

6. Lifting Method

- When the unit is to be lifted and moved, attach ropes to the suspension plates (4 pcs) provided on the top of the unit. When the unit is lifted, the center of gravity tends to shift the unit to one side and so balance, as shown in the figure below, should be achieved. The angles at which the ropes suspended the unit should be at least 60° at the compressor end and at least 45° at the condenser end. Care should be taken to avoid contact with the main unit while carrying. Hook as directly aligned over the center of gravity as possible.

Example unit shown as figure:

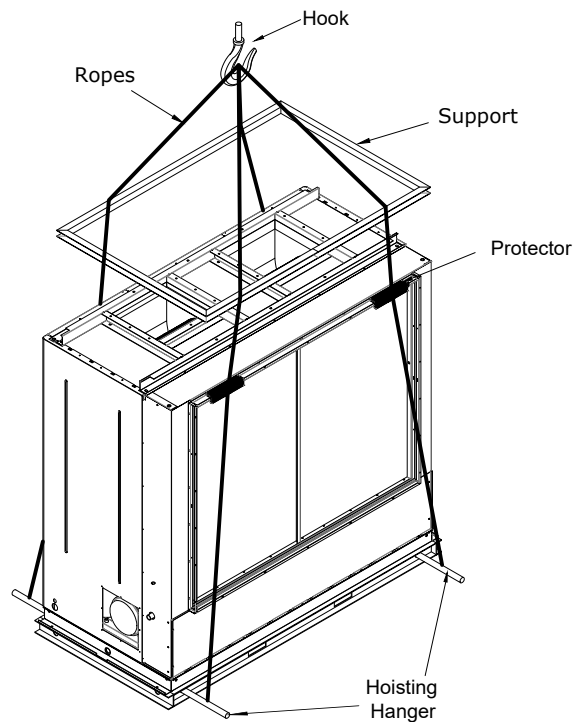

Electrical Parameter R407C

MODEL		FWCP	FWCP15	FWCP20	FWCP25	FWCP30	FWCP35
Power Source		V/Ph/Hz	380~415 /3/50				
Power Cord	Main Line (R/S/T)	Sectional area(mm2)	4.0	4.0	6.0	10.0	10.0
		Quantity	3				
	Null Line	Sectional area(mm2)	4.0	4.0	6.0	10.0	10.0
		Quantity	1				
	Ground Line	Sectional area(mm2)	4.0	4.0	6.0	10.0	10.0
		Quantity	1				
Fuse Size and MCB		A	40	50	63	80	100
		Quantity	1				

MODEL		FWCP	FWCP40	FWCP45	FWCP50	FWCP55	FWCP60
Power Source		V/Ph/Hz	380~415 /3/50				
Power Cord	Main Line (R/S/T)	Sectional area(mm2)	16.0	25.0	25.0	25.0	25.0
		Quantity	3				
	Null Line	Sectional area(mm2)	16.0	25.0	25.0	25.0	25.0
		Quantity	1				
	Ground Line	Sectional area(mm2)	16.0	25.0	25.0	25.0	25.0
		Quantity	1				
Fuse Size and MCB		A	100	125	160	160	160
		Quantity	1				

MODEL		FWCP	FWCP65	FWCP70	FWCP80	FWCP90	FWCP100
Power Source		V/Ph/Hz	380~415 /3/50				
Power Cord	Main Line (R/S/T)	Sectional area(mm2)	125.0	35.0	50.0	70.0	95.0
		Quantity	3				
	Null Line	Sectional area(mm2)	125.0	35.0	50.0	70.0	95.0
		Quantity	1				
	Ground Line	Sectional area(mm2)	125.0	35.0	50.0	70.0	95.0
		Quantity	1				
Fuse Size and MCB		A	200	200	200	250	400
		Quantity	1				

Servicing and Maintenance

Servicing Method

To prolong the lifespan of air conditioner and also to reduce unnecessary down time, it is strongly recommended to perform the following scheduled maintenance and servicing.

Routine Maintenance

- To check the belt tension and alignment, replace belts if necessary
- To check if the belts, screws and wire connections are securely tightened
- To make sure that there is no blockage of filter, condensate water pipe and heat exchanger
- To check if the fan and motor are well lubricated
- Inspect and clean filter periodically, change fi if necessary
- Check coil condition and clean the coil with warm water. At least once a year, perform thorough coil cleaning (Example: Chemical Cleaning) to restore the coil condition
- Inspect and clean water strainers, replace if necessary
- To check operation of all safety controls
- To check if the temperature setting and control setting are correct

Condenser

Frequency of cleaning very much depends on the cooling water quality. One way to determine if it is time to service the condenser is to check if the condensing pressure of the system is too high. However, high head pressure alone does not mean a fouled condenser. The following possibilities should be checked before the condenser cleaning process:

- Refrigerant overcharge
- Incondensable gas in the system
- Faulty head pressure gauge
- Defective water regulating valve
- High entering water temperature to condenser

Note: If a cooling tower is operated with insufficient overflow, the resulting mineral concentration of water can cause rapid and heavy fouling inside the condenser tubes. This condition will prompt frequent cleaning and could lead to severe corrosion. Double check the system to make sure that fouling is actually causing the trouble.

The construction of tube-in-tube condenser does not allow it to be cleaned mechanically. However, chemical cleaning could be adopted, by the following:

- Use only chemical additives from authorized dealer
- Use the right amount of chemical according to cleaning direction. And follow exactly the cleaning or neutralizing procedure after cleaning.
- It is recommended to engage professional water treatment personnel to perform chemical cleaning.

<p>CAUTION: EXCESSIVE TREATMENT AND INAPPROPRIATE CHEMICAL CLEANING OF WATER CAN CAUSE MORE HARM THAN GOOD. DAMAGE COULD BE DONE TO OTHER SYSTEM COMPONENTS LIKE PUMP, COOLING TOWER, PIPING, ETC.</p>

Maintenance Checklist

Item	Method
<u>Recommended Monthly Maintenance Checklist</u>	
Air Filter	Clean dirty filters
Drain Pan	Check if drain pan has excessive water or water frost, water frost could be due to insufficient air flow
Drain Pipe	Make sure there is no blockage on drain pipe
Strainer	Clean strainer if dirty or clogged
Fan & Motor	Make sure blower and motor fittings are strong enough for unit operation Check belt tension and alignment
Internal Compartment	Check for refrigerant leak
<u>Recommended Six Monthly Maintenance Checklist</u>	
Blower Wheel	Disconnect all power supply, check if the blower wheel could turn freely without obstruction manually. Check the blower and motor shaft alignment, make sure the blower wheel fittings are strong enough
<u>Recommended Yearly Maintenance Checklist</u>	
Unit Structure	Make sure all the panel fittings and fixing structures are strong enough
Wiring connection	Check tightness of wiring connections, contactors and relays within control panel
Heat exchanger	Remove water from heat exchanger, check if there is any blockage of dirt inside, clean the heat exchanger

Troubleshooting

Preliminary Inspection

In the event of unit malfunction, be sure to perform the preliminary checks before referring to the troubleshooting chart.

- Verify that the unit is receiving electrical power supply.
- Ensure that the fuses in the fused disconnect are intact.
- Inspect the unit for other obvious problems such as leaking connection, broken or disconnected wires, etc.

If everything appears to be in order, but the unit still fails to operate properly, refer to the troubleshooting chart.



WARNING: ELECTRICALLY ISOLATE THE UNIT BEFORE COMMENCING ANY WORK!

For increased safety, place suitable notices to prevent other personnel from inadvertently restoring the power supply.

Caution:

- Never allow main voltage to be applied to any connection to the controller, otherwise it may be irreparably damaged.
- No field repairs to the controller should be attempted.

Fault	Possible Causes	Remedial Actions
Insufficient Cooling Capacity	a. Compressor faulty	Check compressor and change if necessary
	b. High load (Entering Air Temp too high)	Increase number of unit or change to higher capacity unit
	c. Condenser or evaporator coil dirty	Clean the condenser and/or evaporator coils
	d. Refrigerant not sufficient	Check the cause of leaking and add refrigerant
	e. Low airflow through evaporator	Adjust the tension of fan belt and make sure airflow is normal
	f. Indoor room sensor faulty	Check room sensor and change if necessary
Compressor Trip	Low Pressure Protection	
	a. Reduced airflow through evaporator	Check and clean evaporator and fan motor
	b. Refrigerant not sufficient	Check the cause of leaking and add refrigerant
	c. Cooling water temperature too low or water flow rate too high	Check cooling tower and reduce water flow rate if necessary
	d. Refrigerant pipe blocked	Find out the blockage and correct the problem
	e. Low pressure switch faulty	Replace low pressure switch
	High Pressure Protection	
	a. Incondensable gas in the refrigerant circuit	Re-vacuum and refill refrigerant
	b. Too much refrigerant	Adjust the refrigerant level
	c. Cooling tower too small, poor cooling capacity	Reselect the cooling tower
	d. Cooling water flow rate too low	Increase cooling water flow rate
	e. Heat exchanger dirty causing poor heat exchange	Clean the water system
	f. High cooling water temperature	Reduce cooling water temperature
	g. High pressure switch faulty	Replace high pressure switch
	Compressor Overload Protection	
	a. Compressor over-current (voltage too low or phase lost)	Check power supply, contactor and wire connection and repair if necessary
b. Discharge pressure too high, cooling water flow rate is not smooth	Ensure water flow prior to system start	
c. Return air temperature high or high air flow	Reduce return air volume	
d. Compressor short body	Replace compressor	
Fan Motor Noisy	a. Fan belt slipping	Adjust belt tension
	b. Fan motor pulley misalignment	Adjust fan pulley
	c. Motor or fan blower lack of lubrication oil	Add lubrication

Note : This information is provided for guidance only and is not exhaustive. Please contact your local dealer/service personnel if the faults persist.

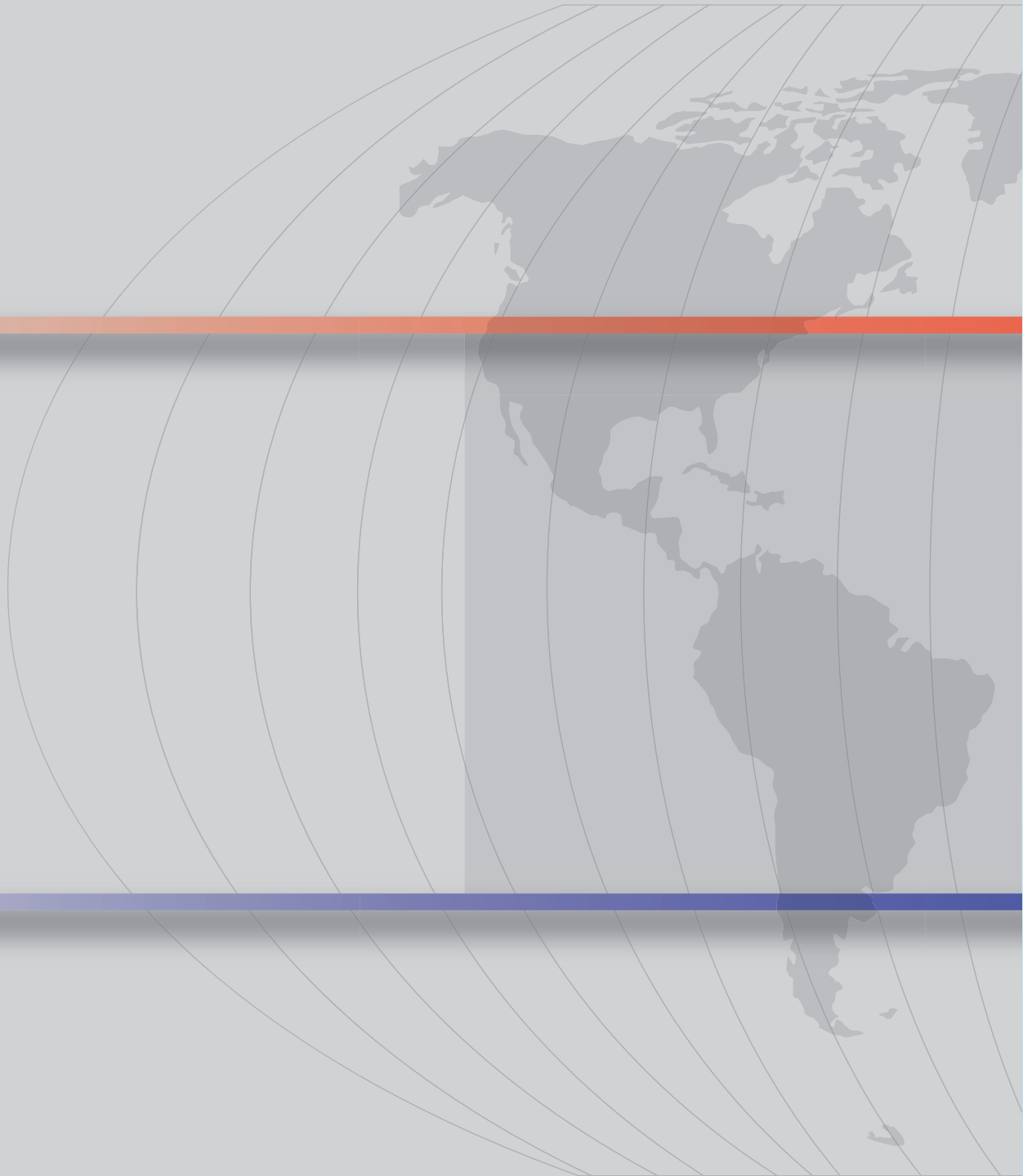

A member of FRIMEC International Group